



## **Peakup Power Installation Manual**

# Contents

1 Summary .....	1
1.1 Disclaimer.....	2
1.2 Codes and regulations.....	2
1.3 Module information.....	3
1.3.1 Encapsulation structure drawing .....	3
1.3.2 Module drawing.....	3
1.3.3 Module identification .....	3
2 Safety precautions.....	4
2.1 Electrical safety .....	4
2.2 Fire safety .....	6
3 Mechanical / electrical properties .....	7
4 Storage and unpacking.....	8
4.1 Transportation and storage safety .....	8
4.2 Operating safety.....	9
5 Installation.....	9
5.1 Precautions and general safety rules .....	9
5.2 Environmental conditions .....	10
5.3 Installation requirements.....	10
5.4 Optimal orientation and inclination.....	12
5.5 Avoid shadows .....	12
5.6 Module wiring.....	13
5.6.1 Correct electrical wiring.....	13
5.6.2 Correct connection of the MC4 connector .....	14
5.6.3 Use appropriate material .....	14
5.6.4 Cable protection.....	15
5.6.5 Bypass diodes.....	15

5.7 Grounding .....	15
6 Installation instructions.....	16
6.1 Module and tools .....	16
6.1.1 Module .....	16
6.1.2 Construction materials.....	16
6.2 Unpacking, Handling and Checking Precautions .....	17
6.3 Construction Precautions.....	18
6.4 Precautions and Tips for Gluing Modules .....	19
6.5 Flat Roof Construction Scheme.....	19
6.5.1 Supporting material Installation Method (using sub-construction longitudinal) .....	20
6.5.2 Supporting material Installation Method (using sub-construction horizontal) .....	24
6.5.3 Installation method of laying directly along the roof (paste longitudinally) .....	29
6.5.4 Installation method of laying directly along the roof (paste horizontally) .....	33
6.6 Metal roof construction scheme.....	36
6.6.1 Trapezoidal color steel tile roof installation method 1 .....	37
6.6.2 Trapezoidal color steel tile roof installation method 2 .....	44
6.6.3 Trapezoidal color steel tile roof installation method 3 .....	49
6.6.4 Trapezoidal color steel tile roof installation method 4 .....	54
6.7 Vertical wall Construction Scheme .....	61
6.7.1 Facade installation method (Longitudinal) .....	61
6.7.2 Facade installation method (Horizontal).....	65
6.8 Wiring and testing.....	70
7 Maintenance and repair.....	71
7.1 Maintenance .....	71

7.2 Repair .....	73
7.3 Cleaning and method recommended .....	73
Annex A: Unpacking .....	75
Annex B: Model and electrical performance parameters.....	78
Annex C: Gluing operation specification.....	78
1. Gluing nozzle cutting .....	78
2. Operation steps.....	79
3. Gluing parameters.....	80
4. Structural adhesive form.....	81

# 1 Summary

Thank you for choosing Peakup Power as your PV module provider. This manual applies to Solar Photovoltaic Flexible Modules (here after referred to as “Modules”) manufactured by Jiangsu Peakup Power Corp., Ltd. (here after referred to as “Peakup”). Professional skills and knowledge are required for the installation. Only qualified installers after proper training can assume this job. Installers should follow all safety precautions described in this manual as well as local codes when performing installation and maintenance.

You must read carefully and be familiar with this manual before handling, installing, and/or maintaining. This manual contains important information such as safety, installation, maintenance of modules, and other relevant information.

This manual is not in a form of any types of warranty document, expressed or implied. It does not stipulate compensation scheme of any loss, damage or other expenses caused by or generated during module installation, operation or maintenance. Peakup assumes no responsibility for any infringement of patents or other rights of third parties, which may result from using Peakup modules. Peakup reserves the right to make changes to its products or this manual without prior notice.

Peakup is not responsible for any damages caused by inappropriate installation, use, or maintenance of Peakup modules, including without limitation damages, losses, and expenses caused by non-observance of the instructions of this manual or caused by or in connection with products of other manufacturers.

Failure to comply with the requirements listed in this manual will invalidate the Limited Warranty for modules as provided by Peakup at the same time of sales to the direct customers. Additional recommendations are provided to enhance safety practices and performance results. Please provide a copy of this manual to the PV system owner for their reference, and inform them all relevant aspects of safety, operation and maintenance.

This Installation and User Manual is available in different languages. In cases of

discrepancy between versions, the Chinese language version shall prevail.

## **1.1 Disclaimer**

As the use of this manual and the conditions or methods of installation, operation, use and maintenance of photovoltaic products are beyond the control of Peakup, Peakup shall not be responsible for any loss, damage or expense arising from any operation related to such installation, operation, use or maintenance.

Any infringement of third-party patents or other rights that may result from the use of PV products does not fall within the scope of Peakup's responsibility. The Customer does not obtain any patent or patent rights authorization for the use of Peakup products.

The information in this manual is based on the knowledge and proven experience of Peakup. However, such information and advice, including (without limitation) product specifications, does not constitute any warranty or warranty, express or implied. Peakup reserves the right to change the contents of this installation manual without prior notice.

## **1.2 Codes and regulations**

The mechanical and electrical installation of PV systems should be performed in accordance with all applicable codes, including electrical codes, building codes, and electric utility interconnect requirements. Such requirements may vary for mounting location. Requirements may also vary with system voltage, and for DC or AC application. Contact local authorities for detailed governing regulations, acquire confirmation and relevant permission.

## 1.3 Module information

### 1.3.1 Encapsulation structure drawing

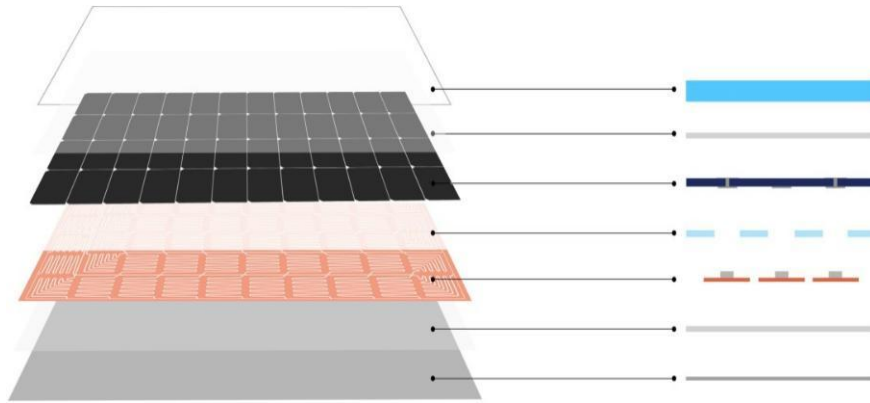

### 1.3.2 Module drawing

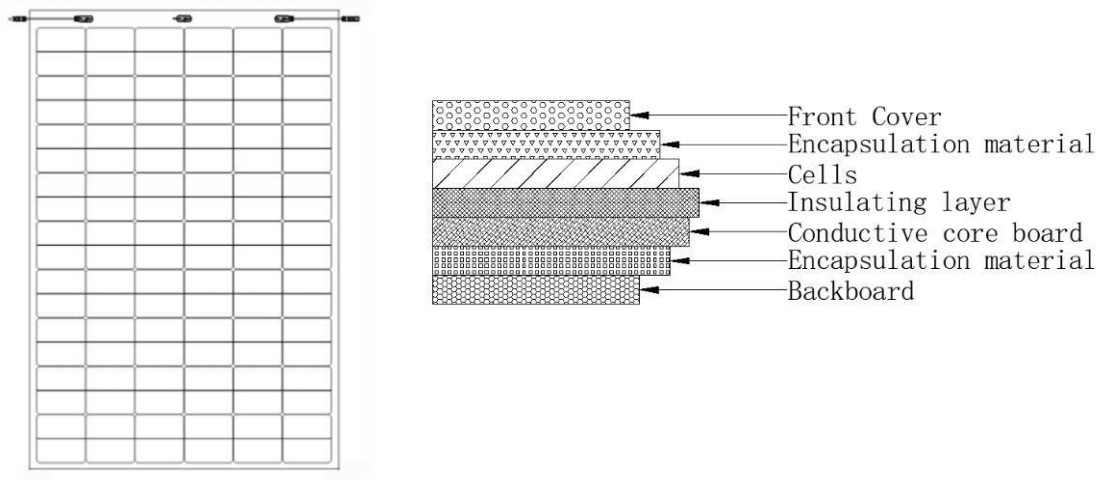

Fig 1 Module structure layers

### 1.3.3 Module identification

Each module has a unique serial number composed of 12 digits and letters.



Fig 2 Module barcode label

There is a nameplate on the front of each module, which indicates the module's model, main electrical performance, maximum power, optimal operating current, optimal operating voltage, open circuit voltage, short-circuit current, certification mark, and maximum system voltage under standard test conditions.



Fig3 Module nameplate

## 2 Safety precautions

Peakup's Flexible modules are designed to meet with the requirements of IEC 61215 and IEC 61730. The application class is A, meaning the modules can be used in system of 30Vdc or 400W or higher, to which the general public may have access. Peakup's modules also meet the requirement of IEC61730-1 and IEC 61730-2 and qualified for Safety Class II.

Peakup's flexible modules meet the requirements of DIN EN 13501. According to the DIN EN 13501-1 standard, they meet the Class E requirement. As evaluated under DIN EN 13501-5, the test results satisfy the BROOF (t1) classification. Among these, the second-generation products are suitable for roofs with a slope of <math><20^\circ</math>, while the third-generation products can be applied to roofs of all slopes.

### 2.1 Electrical safety

In case that no load or external circuit being connected, photovoltaic modules

can produce DC electricity when exposed to light and therefore can produce an electrical shock or burn. DC voltage of 30 Volts or higher is potentially lethal. Please use insulated tools and rubber gloves when working with modules in sunlight



Modules have no on/off switch. Modules can be rendered inoperative only by removing them from sunlight area, or by fully covering their front surface with cloth, cardboard, or other completely opaque material, or flipping Modules, and placing the front side of Modules onto a smooth, flat surface.

In order to avoid arcs and electrical shock, please do not disconnect electrical connections under load. Faulty connections can also result in arcs and electrical shock. So please keep connectors dry and clean, and ensure that they are in proper working condition. Never insert any other metal objects into the connector, or modify them in any way in order to secure an electrical connection.

Do not touch the modules which junction box is failed off or other damaged unless the modules are disconnected in advance and you are wearing proper PPE. Avoid handling modules when they are wet unless cleaning the modules as directed in this manual. Never touch electrical connections that are wet, without PPE or insulated gloves.

Reflection from snow or water can increase sunlight and therefore increase current and power. In addition, low environmental temperature can also substantially increase voltage and power.

## 2.2 Fire safety

Please consult the local laws and regulations regarding fire protection requirements before installing the modules. According to the IEC 61730-2 standard, the fire rating of the Peakup's second-generation module is classified as Class C (The fire rating of the third-generation module is Class B). Please use appropriate



accessories in accordance with local regulatory requirements, such as fuses, circuit breakers, grounding connectors, and others.

During rooftop installation, Peakup's flexible modules can be installed directly on the roof. Please note, however, that for slopes  $< 20^\circ$ , both second and third-generation products are applicable, while only third-generation products can be installed on slopes  $\geq 20^\circ$ . Electric arc may happen when module working due to the wrong installation method or defective module part. Please keep the combustible liquid, gas and dangerous cargo away from the module. You must stop using the module if there is exposed combustible gas nearby.

In the event of a fire, modules may continue to produce a dangerous DC voltage, even if they have been disconnected from the inverter, have been partly or entirely destroyed, or the system wiring has been compromised or destroyed. In the event of fire, inform the fire crew about the particular hazards from the PV system, and stay away from the PV system during and after a fire until the necessary steps have been taken to make the PV system safe.

### Safety rules

- All installation work must be in full compliance with local regulations and corresponding national or international electrical standards.
- Use insulated tools to reduce the risk of electric shock.
- Use appropriate protective measures (slip gloves, overalls, etc.) to avoid direct contact with workers at 30V DC or higher, while avoiding direct contact with sharp

edges during installation to protect the operator's hands.

- Do not wear metal ornaments when installing, to avoid puncturing the modules and causing electric shock.
- If modules are installed or operated on rainy days or dew mornings, appropriate protective measures should be taken to avoid injury to modules and workers.
- When working in rooftop applications, it is imperative not to engage in any activities on the roof without proper safety precautions. Such precautions include, but are not limited to, fall protection measures, the use of ladders or stairs, and the utilization of personal protective equipment.
- Children or unauthorized personnel are not allowed to access the installation area or module storage area.
- If the circuit breaker and overcurrent protection circuit breaker cannot be opened, or if the inverter cannot be turned off during the module installation or wiring, cover the array modules with opaque material to stop the power output.
- Do not use or install damaged modules.
- If the module surface is damaged or worn, direct contact with the surface of the module may result in electric shock.
- Do not attempt to repair any part of the module, there are no user-accessible modules within the module.
- The cover of the junction box shall remain closed at all times.
- Do not split the modules or alter any part of the module.
- Do not artificially condense light on modules.
- Do not connect or disconnect modules when there is current in the module or external current.

### **3 Mechanical / electrical properties**

The rated electrical performance data for the modules is measured under standard test conditions (STC) of irradiance of 1000 W/m<sup>2</sup>, AM 1.5, and cell

temperature of 25 °C. The main electrical performance parameters under STC conditions are also marked on the nameplate of each module. The maximum system voltage for all modules is 1500V.

In some cases, the current or voltage generated by the module may be greater than the optimal operating current or voltage of its standard test condition (STC). Therefore, when determining the module rating and load value, the module open circuit voltage and short circuit current at STC should be multiplied by 1.25. Please check with your local rules and regulations.

## **4 Storage and unpacking**

### **4.1 Transportation and storage safety**

- Do not open the original package during transportation and storage until they are ready to be installed.
- Protect it against damage during transportation.
- Secure the pallets from falling over.
- Do not exceed the maximum stack height limit when stacking as indicated by the symbols outside the package.
- The package shall be stored in a cool and dry location until the modules are ready to be unpackaged.
- Do not carry the modules by the wires or junction boxes of the modules.
- Do not stand, climb, walk or jump on modules.
- Do not allow sharp objects to touch the modules. Scratches can directly affect the safety of the modules.
- Do not leave the modules unsupported or unsecured.
- Do not drop one module onto another.;
- To prevent damage to the battery cells, please do not place any heavy objects on the modules.

- Be cautious when setting the modules down onto a surface, especially on the corner of the modules.

## **4.2 Operating safety**

- The unpacking shall be carried out in accordance with the unpacking steps provided by Peakup (Annex A);
- When unpacking the modules from the original package, first remove the pallet lid (after removing securing straps, if provided). Remove one module at a time. You may need to secure the remaining modules in the original packaging and prevent them from falling over;
- Check modules for damage due to transportation before they are installed;
- Do not install damaged modules. Contact with us if you need to make claim of the defective products.
- Do not attempt to remove any part from the modules;
- Do not apply paint to or stick labels on the module surface;
- Do not scratch on module front sheet to avoid any damage;
- Modules should be handled gently to avoid cell breakage;
- Do not attempt to disassemble or modify the modules for your safety. This may have negative effect on the module quality and safety, even irreversible damage. Additionally, all the warranty will be not available.

## **5 Installation**

### **5.1 Precautions and general safety rules**

- Before installing the modules, please complete a specific site engineering review to ensure the proposed methodology complies with local laws, regulations and or constructions standards.
- Check the applicable building codes to ensure that the building is suitable for

Peakup installation.

- Peakup 's module safety level II (IEC 61730-1) can be used in systems with voltages greater than 30V or power greater than 400W that may be accessible to the public.

## 5.2 Environmental conditions

The modules are suitable for general climatic conditions, i.e. with reference to IEC 60721-2-1 Classification of environmental conditions Part 2-1: Environmental conditions occurring in nature - temperature and humidity.

- If the modules are used in a special installation environment, please consult the technical support department of Peakup in advance. ◦
- The installation surface should be flat without bumps or pits.
- The modules must not be installed near flames or flammable objects.
- Do not expose modules to artificial condensing light sources.
- The modules must not be immersed in water (fresh or salt water) for more than 24 hours, and should not be installed in environments with prolonged water exposure (e.g., fountains, splashing waves) or in areas prone to water accumulation (e.g., puddles, drainage outlets).
- The operational lifespan of the module can be adversely affected by corrosion if deployed in corrosive atmospheres, for example, salt mist (marine environments) or sulfur-laden air (volcanic areas or near sulfur sources)
- **Failure to follow the above precautions, Peakup Warranty will be voided.**

## 5.3 Installation requirements

- Ensure the modules meet the overall technical requirements of the system.
- Ensure that modules of other systems do not cause damaging mechanical or electrical performance effects on the modules.

- Connect modules in series to increase voltage or in parallel to increase current. When connected in series, the positive pole of the module is connected to the next negative pole. When connected in parallel, the positive pole of the module is connected to the positive pole of the next module.
- The number of bypass diodes provided varies depending on the module model.
- Connect the appropriate number of modules according to the voltage specifications of the inverter used in the system. Even at the lowest local temperature conditions, the connected modules must produce no more than the voltage allowed by the system. If overcurrent protection devices (fuse) are not used in series within each string of modules, up to two strings of modules can be connected in parallel. If a suitable overcurrent protection device is connected in series with each string of modules, three strings or more modules can be connected in parallel.
- In order to avoid (or reduce) the mismatch effect of the array, it is recommended to connect modules of similar electrical performance on the same string.
- In order to reduce the risk of indirect lightning strikes, loops should be avoided when designing the system.
- The modules should be securely fixed to withstand all possible loads, including wind and snow loads.
- When installing modules for rooftop applications, it is crucial to consider long-term maintenance. Roofs designated for PV system installation must undergo assessment by construction experts or engineers. Formal and thorough structural analysis results must be obtained in accordance with local requirements, including verifying the roof's capacity to withstand additional loads from the system supports and the weight of the modules.◦
- Movement of the substrate should be taking into consideration when planning the panel layout. Example areas of installation which may cause damage include but are not limited to: different sections of rail and ends of roof sheets.
- Non-compliance with the installation specifications outlined in this manual may

lead to damages such as microcracks in modules or potential fire hazards.

- In order to prevent hail, the second-generation module needs to be installed with full support on the back and must not be installed in the air, otherwise it will not bear the damage caused by the impact of the object. The third-generation modules can be installed suspended according to specific regulations.

## **5.4 Optimal orientation and inclination**

In order to achieve maximum annual power generation, the optimal orientation and inclination of the PV module should be determined first. The maximum amount of power is typically generated when the sun is directly above the PV module.

Peakup recommends installing the modules at a tilt. This facilitates self-cleaning by rainwater, which helps wash away dust and prevents watermarks by promoting rapid drainage. This not only maintains the module's appearance and performance but also reduces the required cleaning frequency. In contrast, flush-mounted installations will necessitate more frequent manual cleaning.

In the northern hemisphere, modules should typically face south, and in the southern hemisphere, modules should typically face north. For detailed installation angles, follow the standard modules installation guide or the recommendations of experienced PV module installers.

## **5.5 Avoid shadows**

Even small shadows (such as dust) can cause a drop in power generation. If all surfaces of the module are uncovered throughout the year, the module is considered "no shadow". Ensure that the sun shines on the modules even on the shortest day of radiation all through the year.

Partial or complete shading of a module or modules can significantly reduce system performance. Peakup recommends installing modules in the place without shade throughout the year to increase the amount of energy produced by the modules.

When designing the module layout, it is necessary to reduce the risk of adjacent PV modules blocking each other, and to avoid the formation of shadows on the surface of the modules when arranging the tray or trunking.

## **5.6 Module wiring**

### **5.6.1 Correct electrical wiring**

Check that the wiring is correct before starting the system. If the measured open circuit voltage (Voc) and short circuit current (Isc) do not match the specifications provided, there may be a wiring fault.

The maximum number of modules that can be connected in a series string must be calculated in accordance with applicable regulations in such a way that the specified maximum system voltage (According to IEC61730 tests and appraisal, the maximum system voltage is 1000Vdc or 1500Vdc depending on the series and model.) of the modules and all other electrical DC modules will not be exceeded in open circuit operation at the lowest temperature expected at the PV system location.

An appropriately rated over-current protection device must be used when the reverse current could exceed the value of the maximum fuse rating of the modules. An over-current protection device is required for each series string if more than two series strings are connected in parallel. These junction boxes have been designed to be easily interconnected in series for their good connected cable and the connector with IP68 protection grade. Each module has two single conductor wires, one positive and one negative, which are pre-wired inside the junction box. The connectors at the opposite end of these wires allow easy series connection of Peakup's modules by firmly inserting the positive connector of a module into the negative connector of a Peakup module until the connector is fully seated.

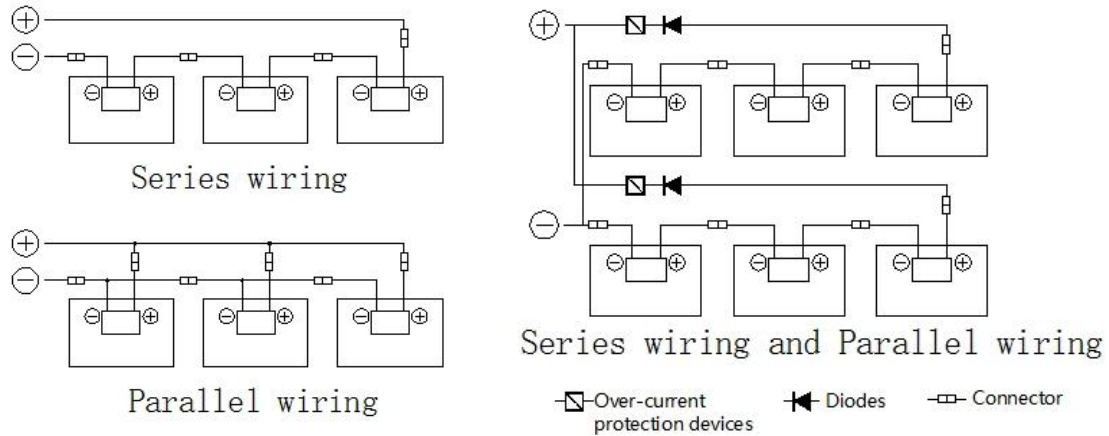

Fig 4 Wiring Methods OCD Diodes Connectors

### 5.6.2 Correct connection of the MC4 connector

Make sure the MC4 connector is secure and properly connected. The tightening torque must be appropriate for the solar cables used. Typical values are between 3.4 Nm and 3.5 Nm (refer to the connector supplier information for specific connection steps). The connector should not be subjected to external pressure. It is solely intended for electrical circuit connections and should not be used to open or close circuits. Do not insert other metal objects into the connector or attempt any other electrical connections.

The MC4 connector should be kept dry and clean to prevent rain and moisture. Avoid water soaking of the MC4 connector.

The junction box and the connector shall not be in contact with organic solvents, oily substances and other corrosive materials that may cause functional failure, to avoid damage to the junction box and the connector. If the junction box and connector are contaminated, they are forbidden to use.

### 5.6.3 Use appropriate material

In accordance with local fire, building, and electrical regulations, it is essential to use specialized solar cables and connectors of the same brand and model as those used by Peakup. Additionally, ensure that the electrical and mechanical performance

of the cables is excellent. ◦

Use field wiring with suitable cross-sectional areas that are approved for use at the maximum short-circuit current of the module. Peakup recommends installers use only sunlight resistant cables qualified for direct current (DC) wiring in PV systems.

(Satisfy the code TÜV 2 PfG 1169、4mm<sup>2</sup>、Temperature range:-40°C to + 90°C) ; Cables should be fixed to the mounting structure in such a way that mechanical damage of the cable and/or the modules is avoided; Do not apply stress to the cables; For fixing, use appropriate means, such as sunlight resistant cable ties and/or wire management clips specifically designed to attach to the modules frame. While the cables are sunlight resistant and waterproof, where possible, avoid direct sunlight exposure and water immersion of the cables.

#### **5.6.4 Cable protection**

Secure the cable with a cable tie that is UV resistant. Appropriate measures should be taken to protect the exposed cable from damage (e.g. in a conduit with UV aging resistance).

#### **5.6.5 Bypass diodes**

The junction boxes used with Peakup's modules contain bypass diodes wired in parallel with the PV cell strings. In the case of partial hot spot, the diodes bypass the current generated by the cells with hot spot, thereby limiting modules heating and performance losses. Bypass diodes are not over-current protection devices. In the event of a known or suspected diode failure, installers or maintenance providers should contact Peakup Never attempt to open the junction box by yourself.

### **5.7 Grounding**

Peakup's modules have no metallic conductors on the outside, and there is no need to set up a grounding system. Please reference to local standards.

## 6 Installation instructions

The following section covers installing instructions for different roofs and facades.

### 6.1 Module and tools

This section covers the modules and the tools and material needed for installation.

#### 6.1.1 Module

Applicable module models and electrical performance parameters are detailed in Annex B.

#### 6.1.2 Construction materials

Cleaning tools, rulers, pay-off tools brushes, primers, Double-sided tape (approximately 2 mm thick, with a certain level of adhesion; brand and specifications are not limited), square tubes, glue guns, structural glue, etc.



Brush Tools



Primer



Double-sided tape

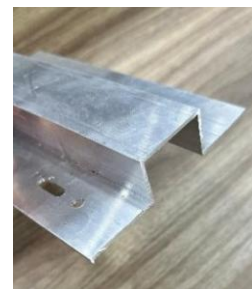

Aluminum profile



square tube



Glue gun



Glue

Remark: The pictures are for reference only

#### List of Uses

Brush Tools: pressing the module to make full contact with the glue, while avoiding damage to the module.

Primer: Bottom layer treatment agent enables better bonding construction of the roof surface layer

Double-sided tape: is used for pre-fixing modules after installation to prevent displacement before structural solidification. 3M HVB double-sided tape with a width of 20mm and thickness of 1mm is recommended. Other brands and models of double-sided tape may also be used, provided the tensile strength is not less than 600 kPa.

Aluminum profile: for vertical installation and application.

Square tube: for roof installation and pasting. The material can be PVC or fiberglass square tube that has obtained fire certification. Support square tubes may use standard procurement lengths, no need to match module length, reducing cutting and saving material & labor.

Glue gun: using for applying Glue.

Glue : using for bonding module. Module installation requires the use of photovoltaic-specific silicone, which must meet four core standards: structural bonding, weather-resistant sealing, electrical safety, and environmental compliance.

## 6.2 Unpacking, Handling and Checking Precautions

- Do not open modules outer Package before installation.

- Check the outer package for damage before unpacking.
- Slip-Proof Gloves are recommended for unpacking and handling.
- Do not grab the modules by the junction box or cables during unpacking or handling.
- Modules should be handled and lifted by at least two people. Do not touch the solar cell area during handling to avoid cell-cracks.
- Be careful while carrying the modules. Avoid hitting the modules on the ground or other sharp, hard objects.;
- Check the surfaces of the modules, make sure there is no damage to the frontsheet and the backsheet.;
- Check the junction box, connectors, and cables for any damage. Double check if the junction box cover is fixed securely.
- Do not paint or apply glue or label on the surface of the modules.

### **6.3 Construction Precautions**

- Before commencing construction, please ensure you have read the adhesive manufacturer's manual to ensure that all the adhesive application requirements are followed. E.g. if you use Tonsan the construction can proceed normally within a temperature range of 5 to 40°C and a humidity level below 80% (The specific construction temperature range should be based on the information provided by the adhesive manufacturer).
- Installation is prohibited during wind conditions of Level 4 (5.5m/s) or higher.
- The surface of the roof must be cleaned or wiped dry, free of floating soil, oil, etc. In order to achieve the required adhesion, the roof must be cleaned using the specified cleaning agents or cleaning agents approved by Pickup.
- After initial installation, the panel and adhesion shall not be disturbed for a minimum of 24 hours. Please refer to adhesive manufacturer's guidelines.
- The paste surface needs to be flat and free of pits or bumps.
- When storing installation material used in installation, it should comply with the

storage specifications for installation material.

- Ensure substrate(s) have been tested and paired to compatible adhesives or bonding procedure. If unsure, please seek clarification from the glue manufacturer or Peakup.

## **6.4 Precautions and Tips for Gluing Modules**

- Please make sure the surface is cleaned and there are no water pits before gluing.
- After applying the glue, the width shall be no less than 10mm and the height no less than 5mm. After bonding, the height of the structural adhesive should be between 3-10mm. It should not be too high or too flat; if too high, the curing time of the structural adhesive will be excessively long; if too flat, the adhesive bond will fail. Do not use foot or any non-designated tools to press down the adhesive. The exact requirements should be referred to those mentioned in the structural assessment and in the adhesive manufacturer's requirements.
- The application of the adhesive should be a continuous and even movement preferable from a caulking gun, using the weight of the module itself to spread the adhesive.
- Make sure to complete the gluing and mounting over a duration that does not exceed 5 minutes.
- Do not apply stress, move modules, or conduct pull-off tests before the structural adhesive is fully cured. Please refer to the technical specifications of the selected glue for its curing time.
- The orientation of the glue caterpillars must follow the direction of water flow.

## **6.5 Flat Roof Construction Scheme**

For flat and pitched roofs, the roof needs to be evaluated by a professional before the modules are installed.

For roofs that are easy to de-powder, it is necessary to use an interface agent to

treat the surface first to ensure that the surface layer will not be delayed before other installation operations. If the surface of the asphalt roof contains a protective film, the film needs to be removed before construction and installation can be carried out. PVC membrane roofing and PVDF coil roof need to evaluate the aging degree and service life of the membrane before installation.

Remarks: The installation steps are illustrated with cement roofs, for reference only, different roof types can refer to this step for construction.

### **6.5.1 Supporting material Installation Method (using sub-construction longitudinal)**

- Clean the installation roof, without particles, dust and other residues;

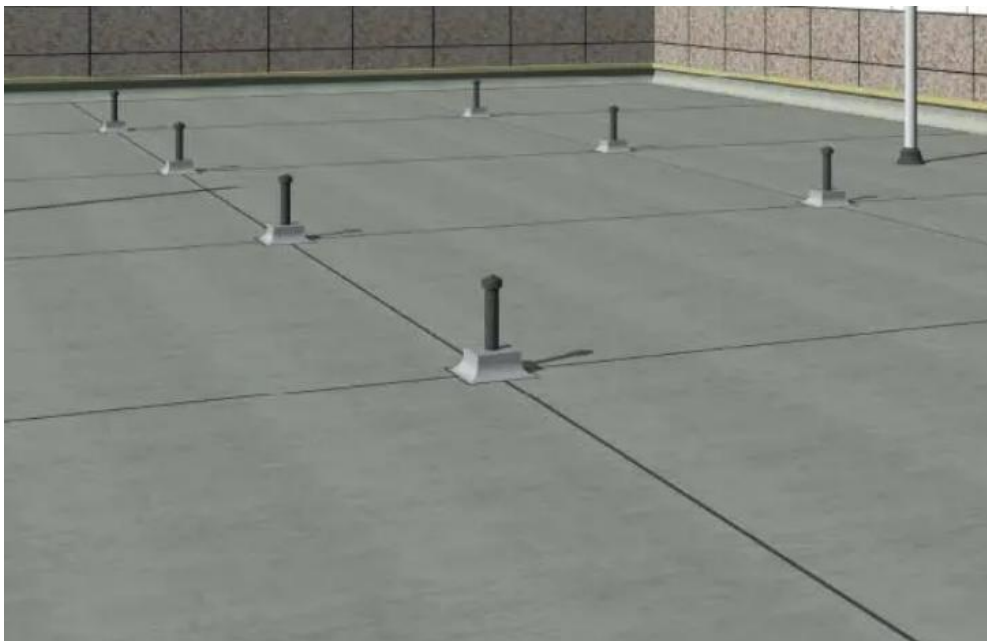

- Drawing identification lines on the roof (Interval 274mm) ;

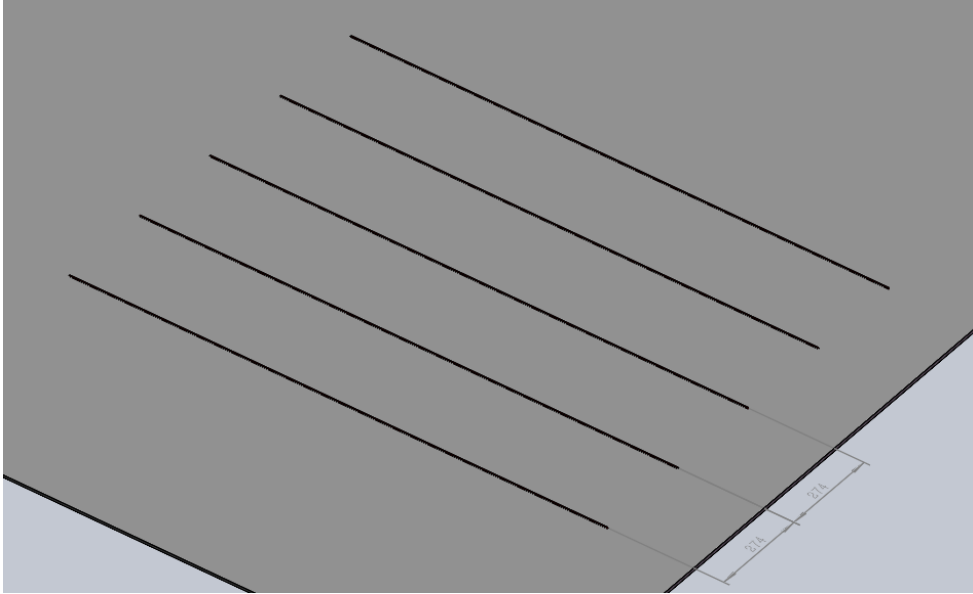

- Printing primer by the lines. Wait for the glue to cure thoroughly;

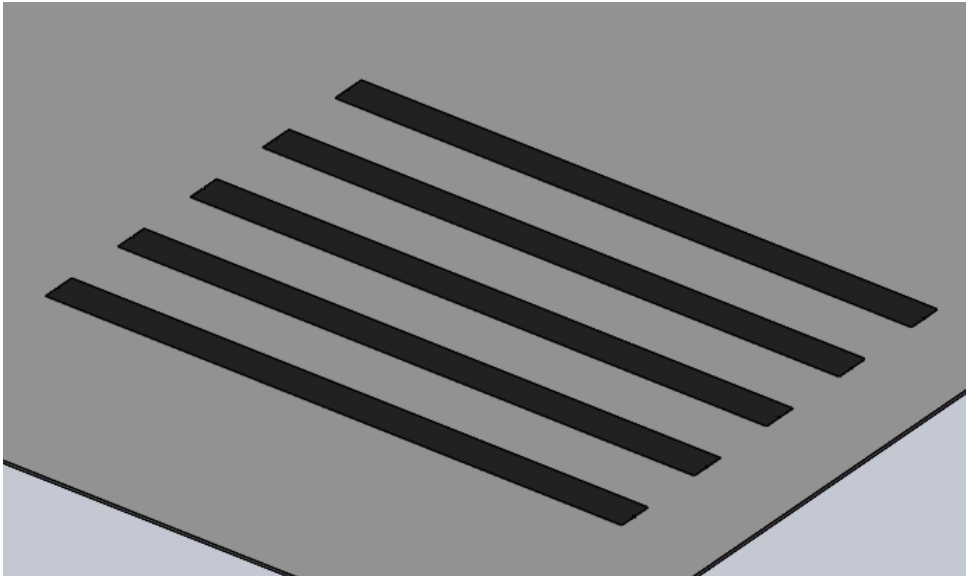

- Gluing on the primer after it's curing;

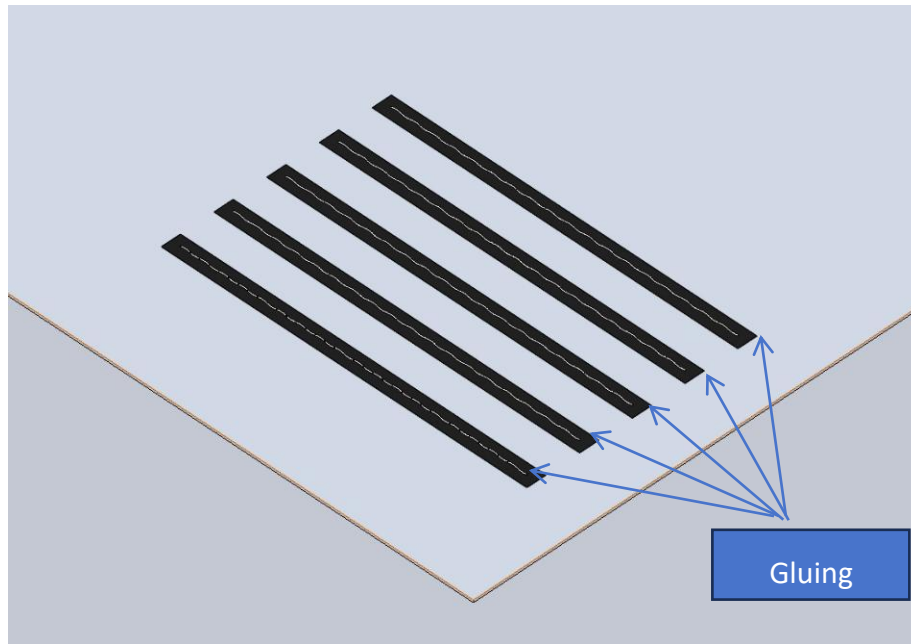

- Lay-up square tube on glue. Curing for 4 hours;

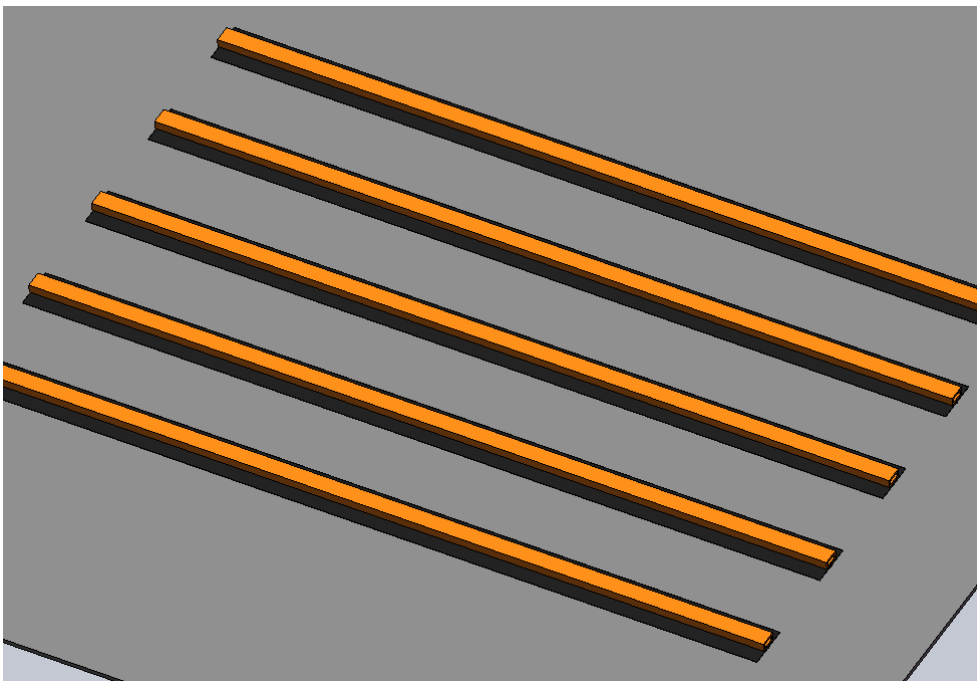

- After the silicone has cured, use the glue gun again to apply the silicone to the upper surface of the square tube;

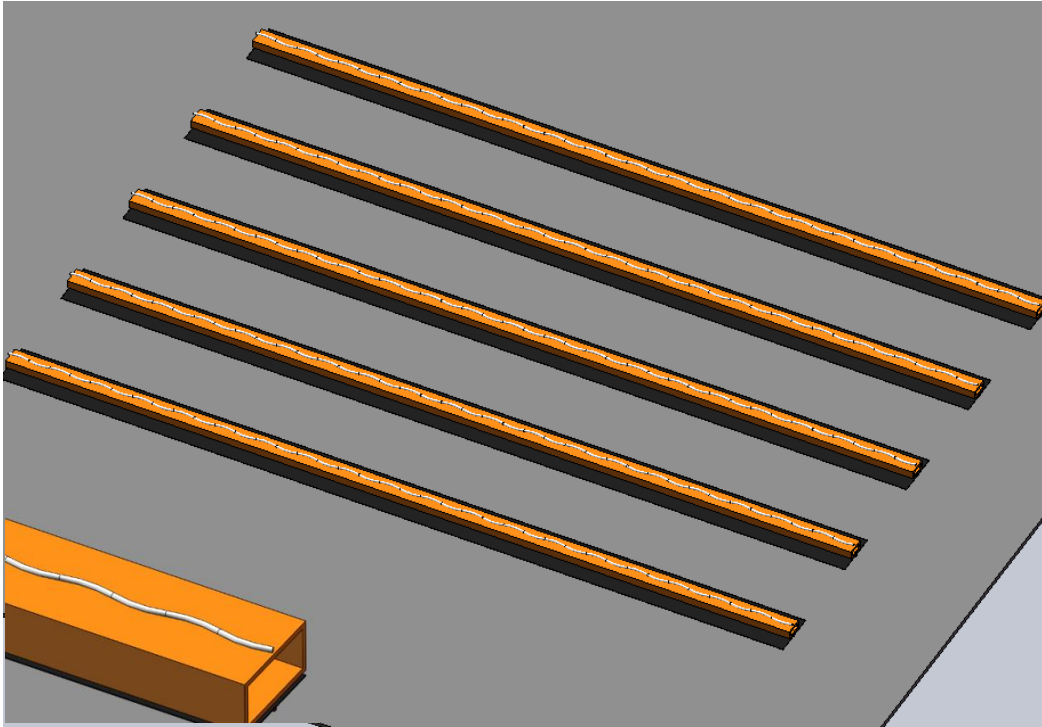

- Install solar module, press carefully by tooling for the gluing parts;

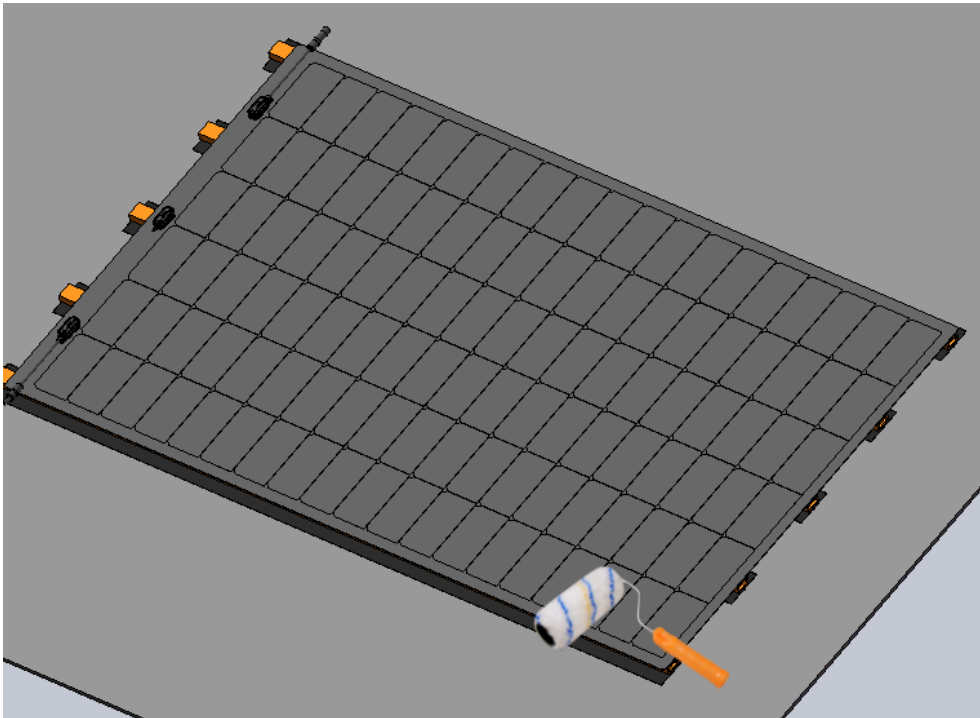

- Repeat the above operation to install other PV modules according to the layout, and connect the positive and negative connectors.

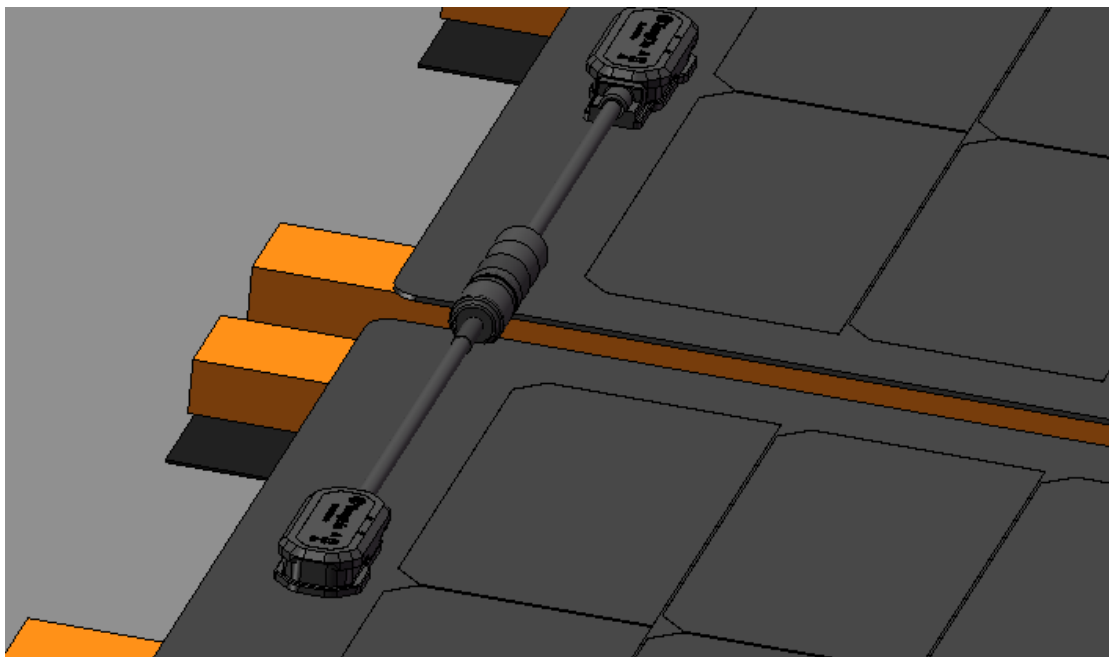
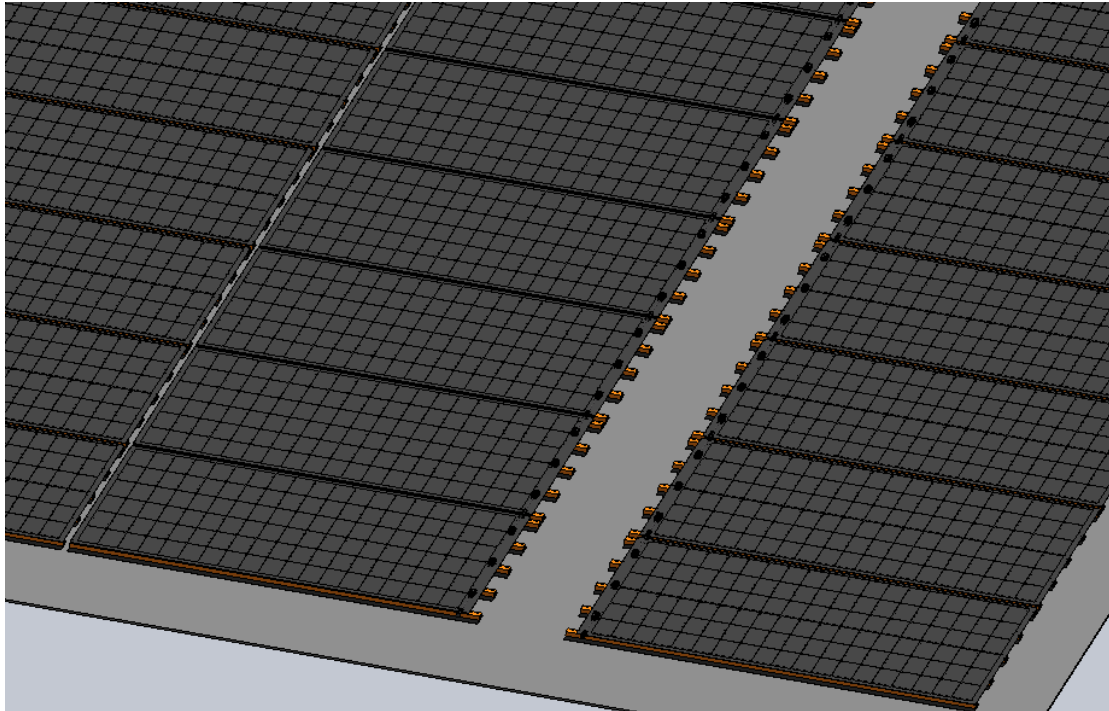

### 6.5.2 Supporting material Installation Method (using sub-construction horizontal)

- Clean the installation roof, without particles, dust and other residues;

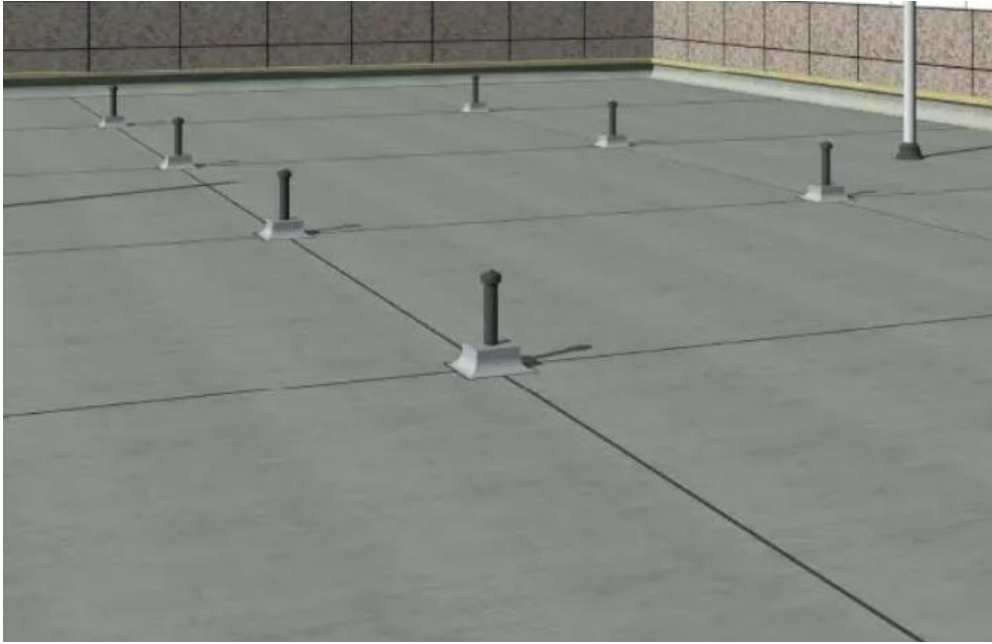

- Drawing identification lines on the roof (Interval 302mm) ;

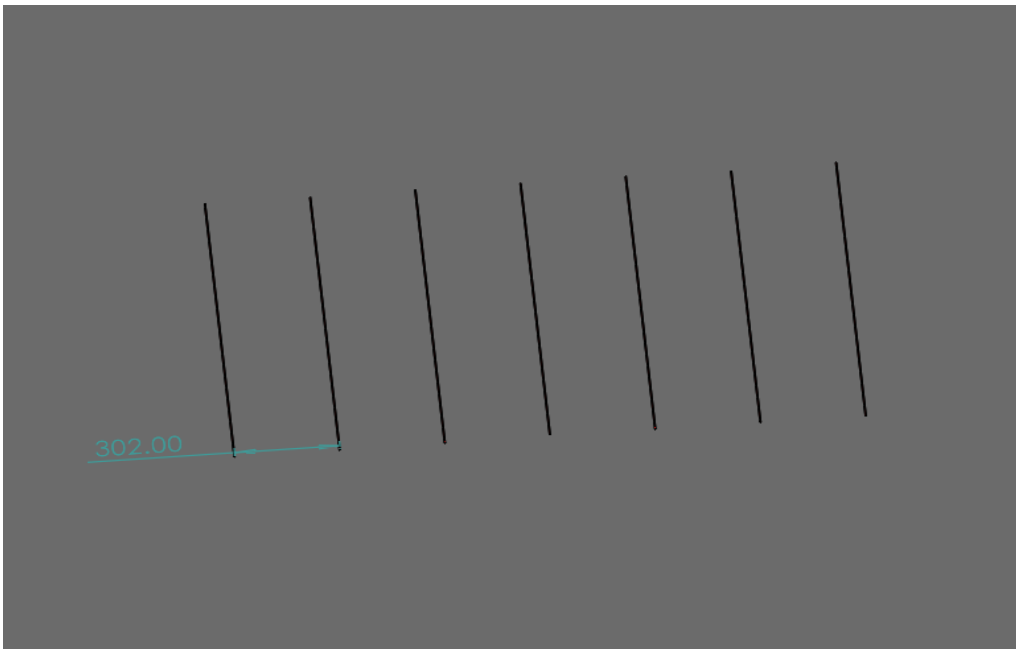

- Printing primer by the lines. Wait for the glue to cure thoroughly;

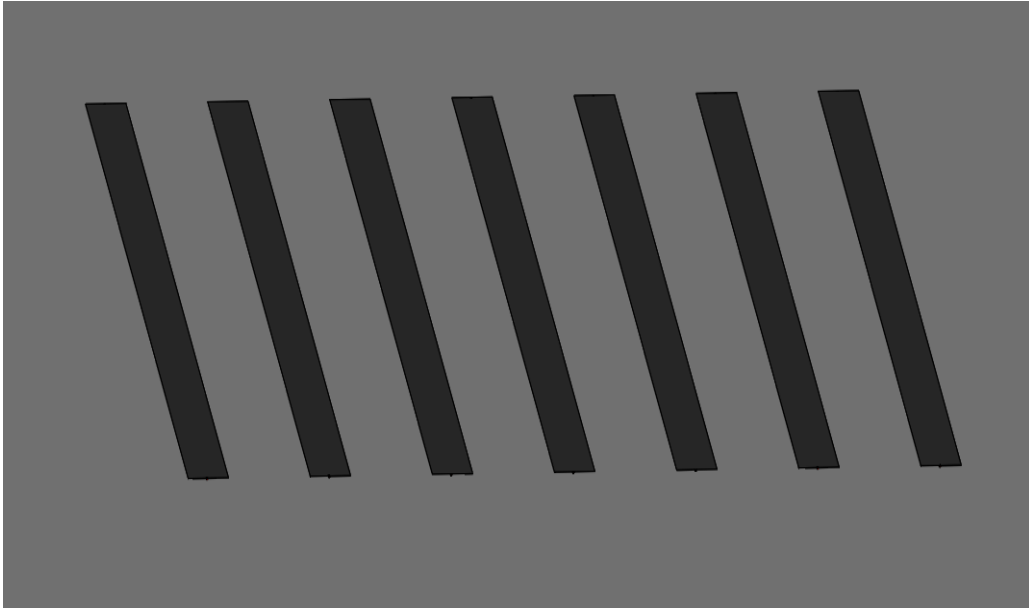

- Gluing on the primer after it curing;

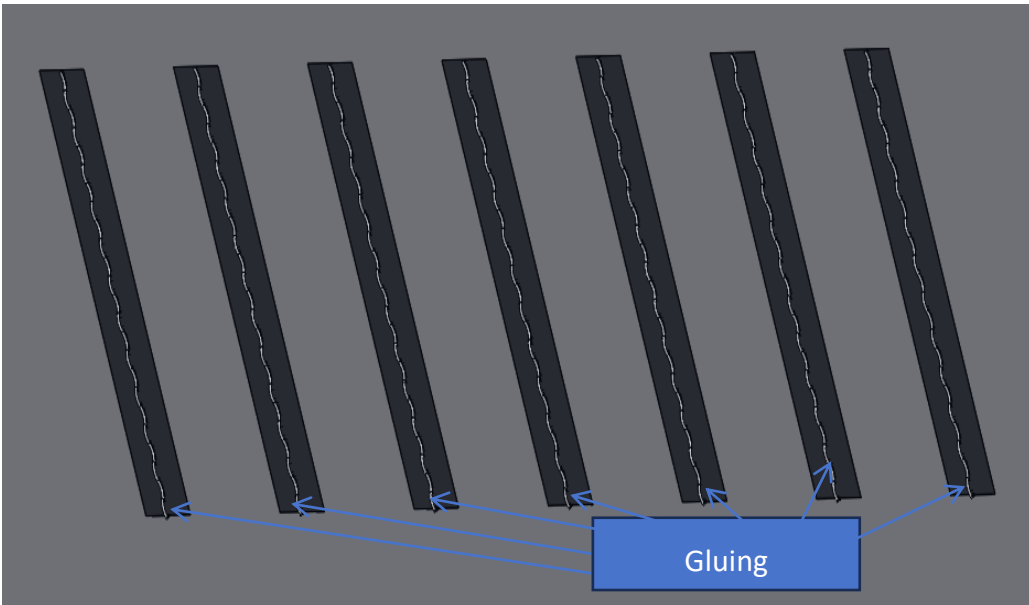

- Lay-up square tube on glue. Curing for 4 hours;

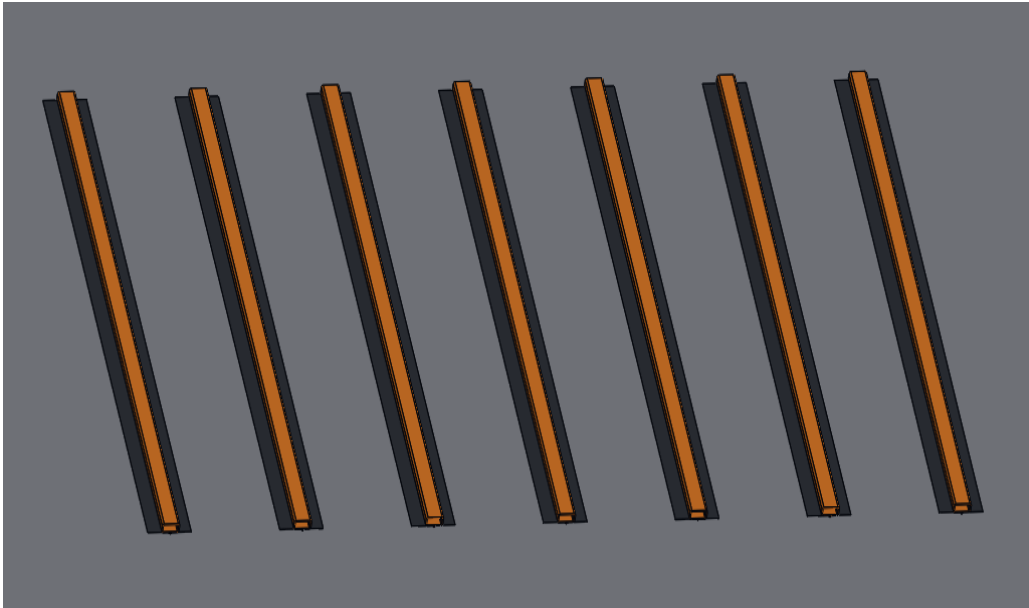

- After the silicone has cured, use the glue gun again to apply the silicone to the upper surface of the square tube;

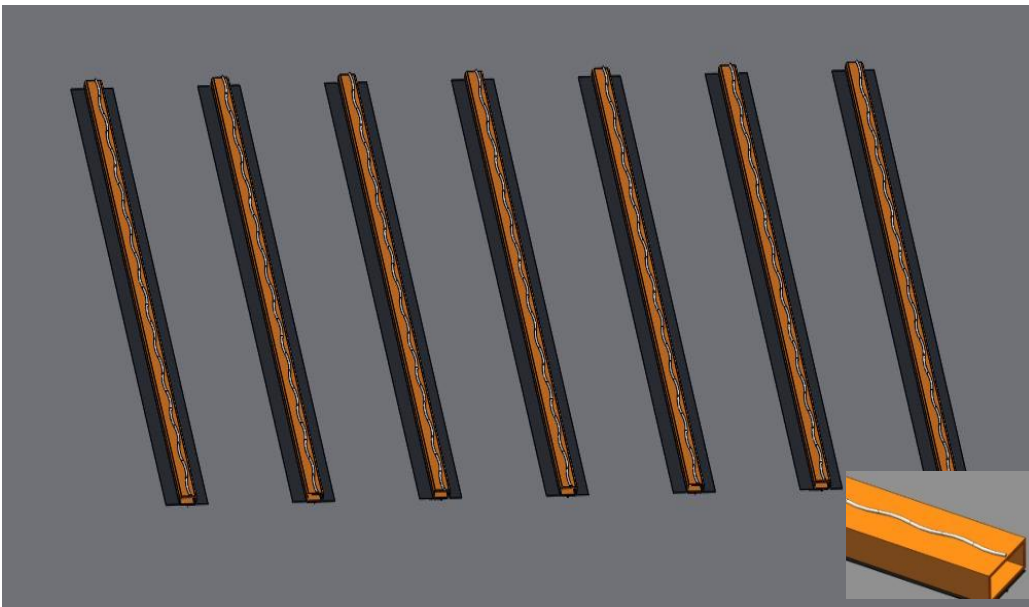

- Install solar module, press carefully by tooling for the gluing parts;

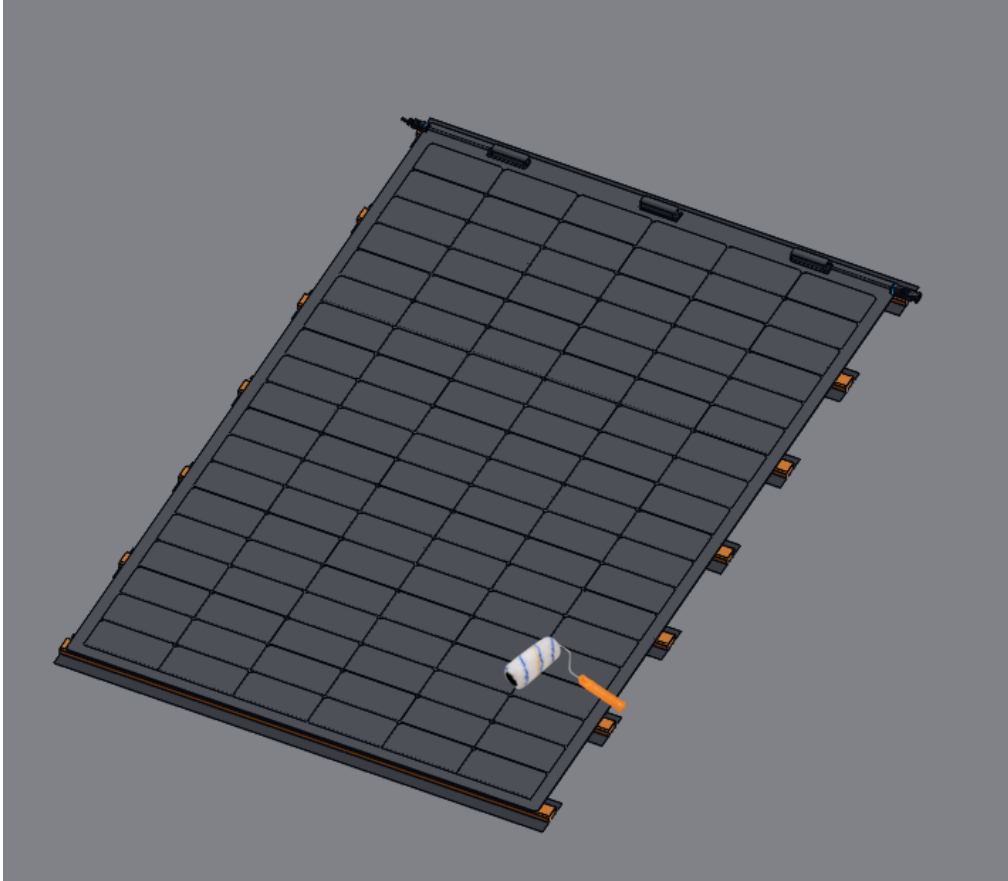

- Repeat the above operation to install other PV modules according to the layout, and connect the positive and negative connectors.

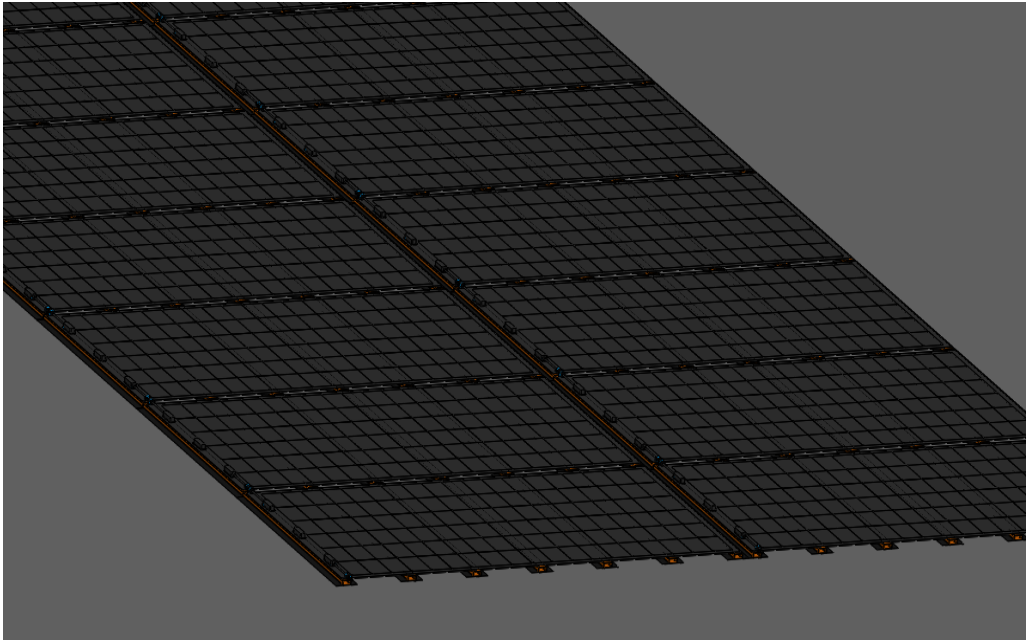

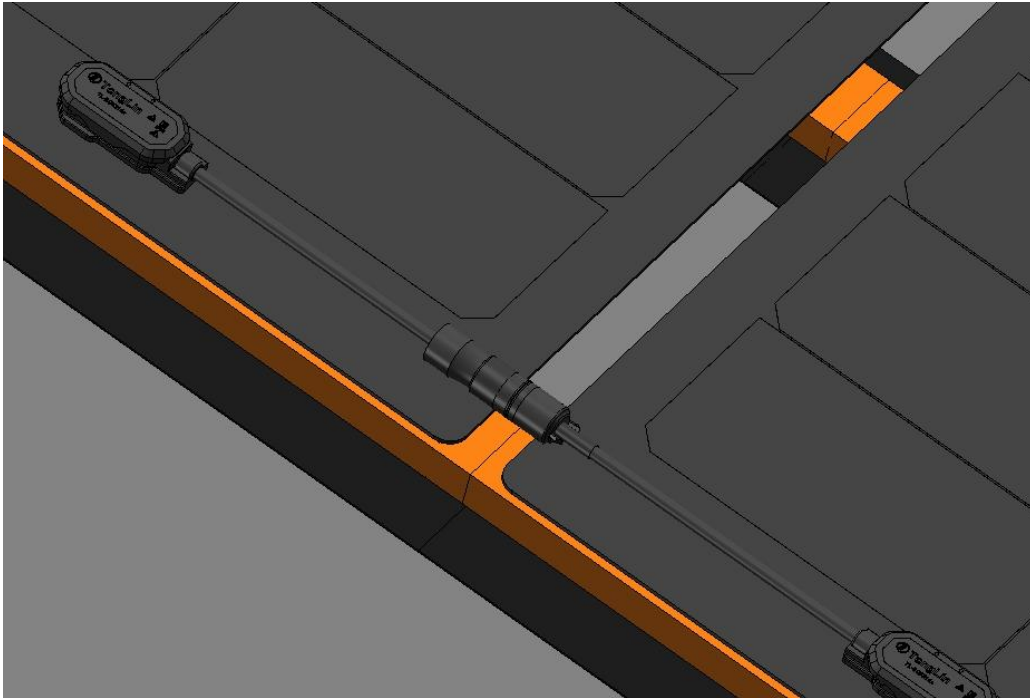

### 6.5.3 Installation method of laying directly along the roof (paste longitudinally)

- Clean the installation roof, without particles, dust and other residues;

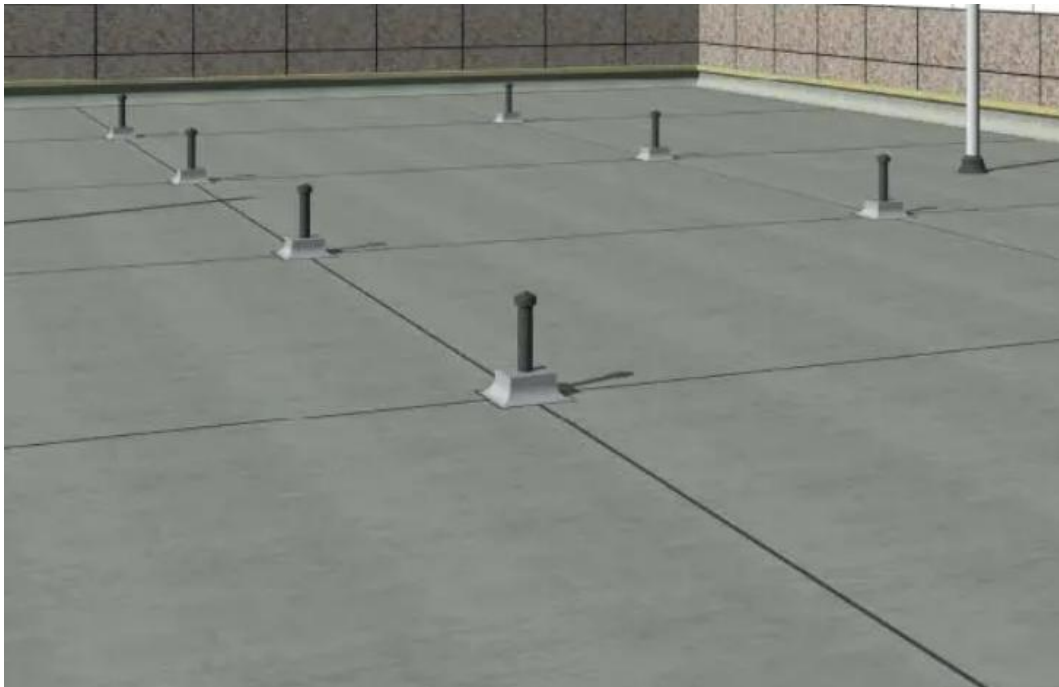

- For cement roofs, the surface is easy to powder, and it is necessary to apply primer on the roof surface first to increase adhesion. First, draw the primer marking line

on the roof (Interval 274mm, the length is the same as the length of the modules used);

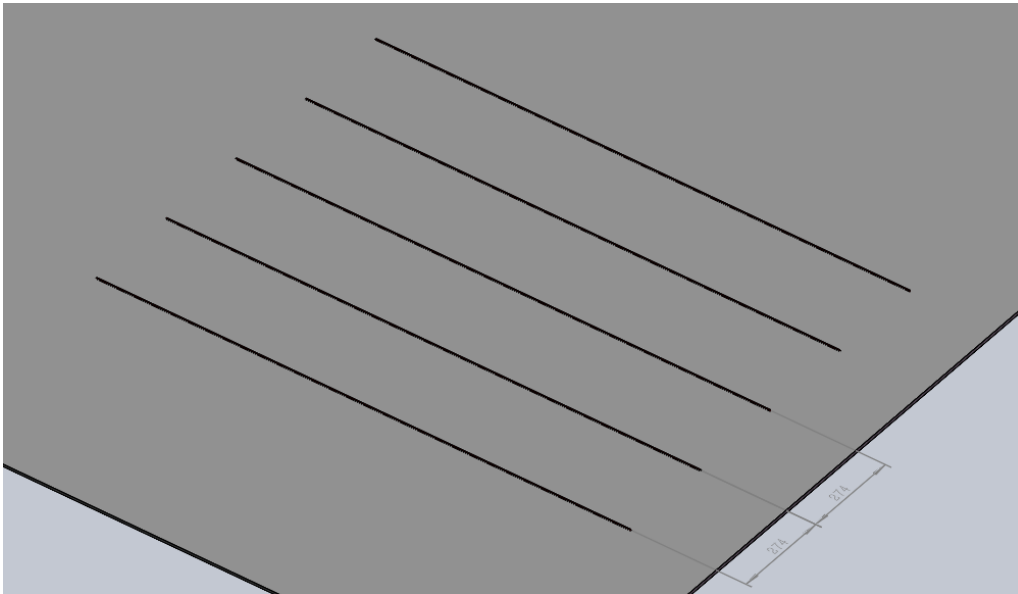

- Brush the primer according to the position of the marking line (if the roof does not need to be brushed with primer, this step can be removed), the width of the primer is not less than 100mm, and wait for the primer to completely cure;

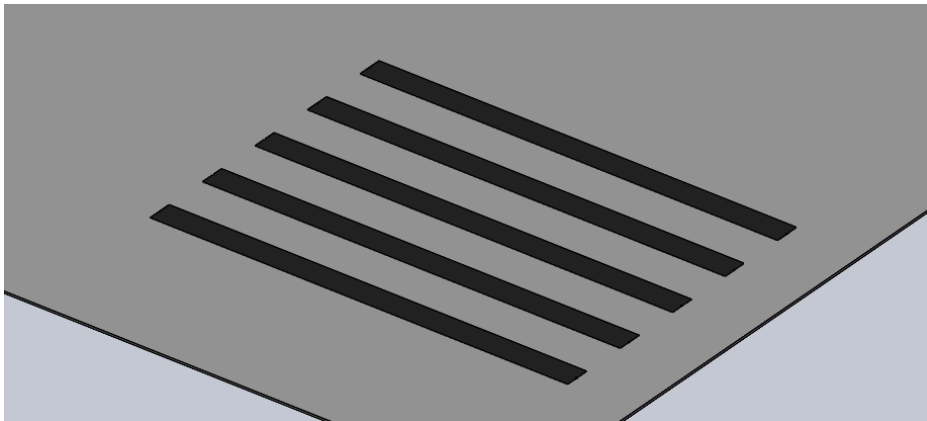

- Paste double-sided tapes on the edge of module;

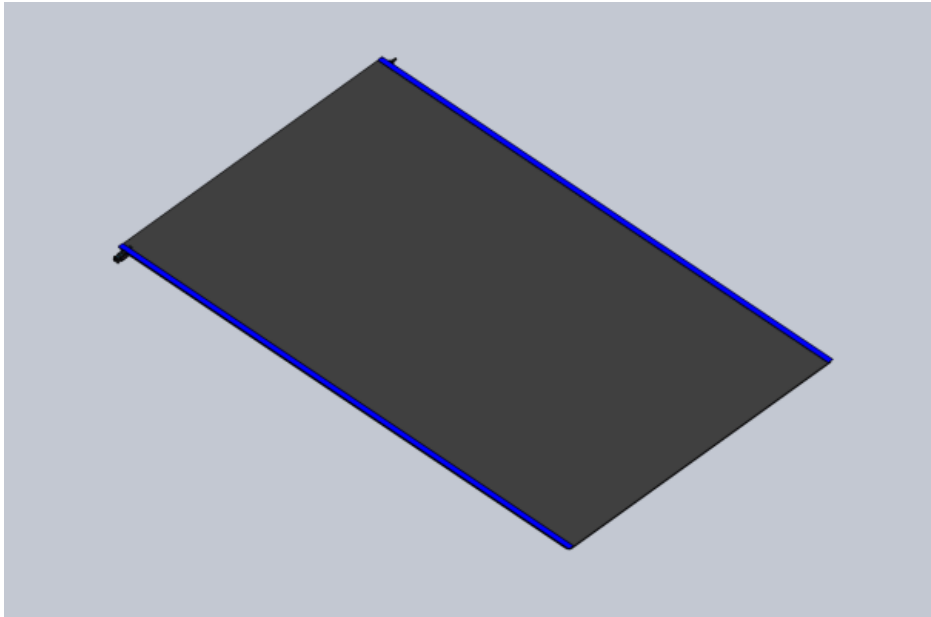

- Gluing on the primer after it curing;

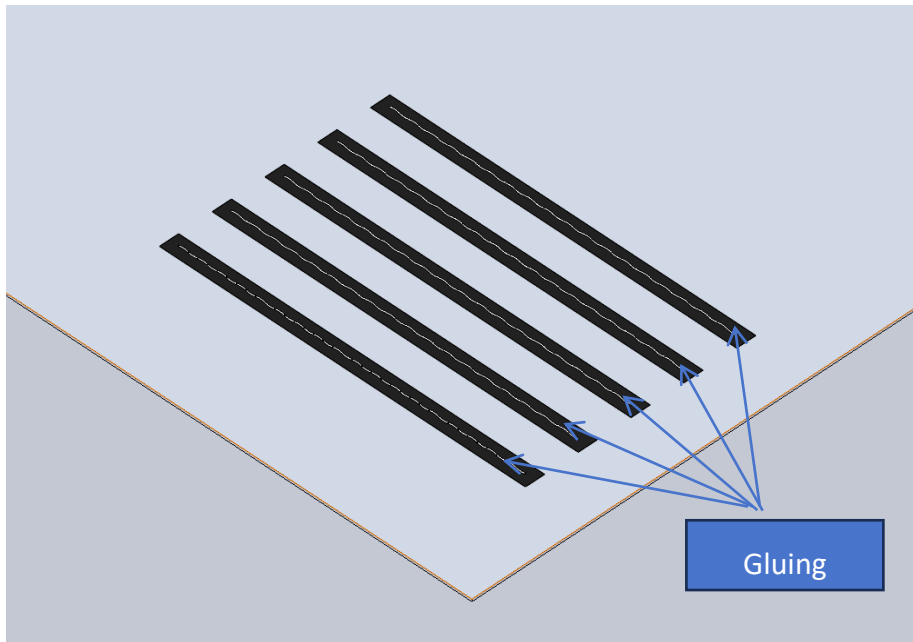

- Install solar module, press carefully by tooling for the gluing parts;

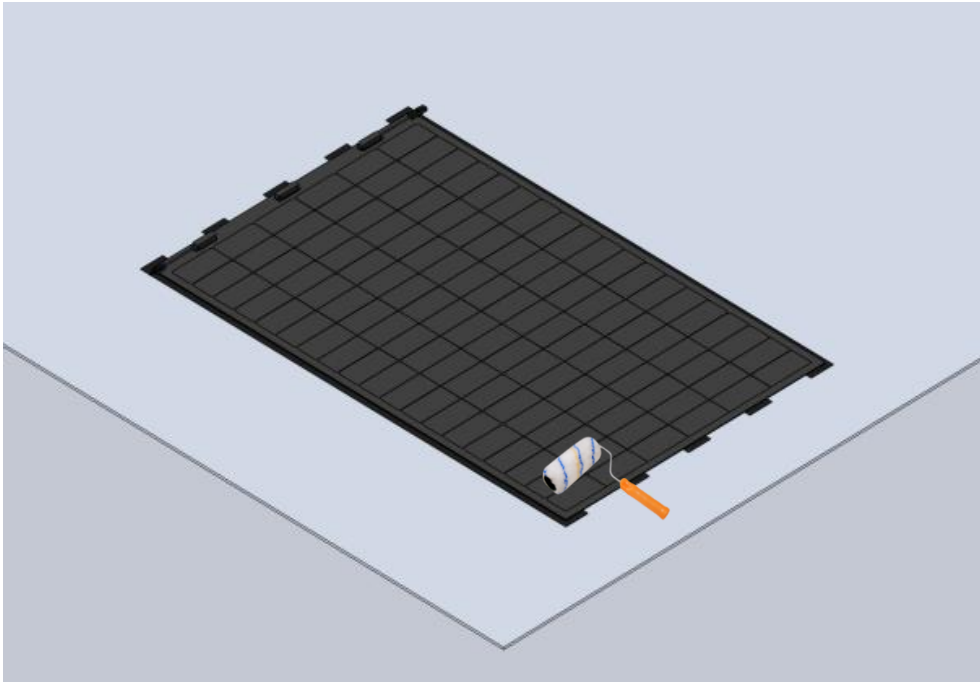

- Repeat the above operation to install other PV modules according to the layout, and connect the positive and negative connectors.

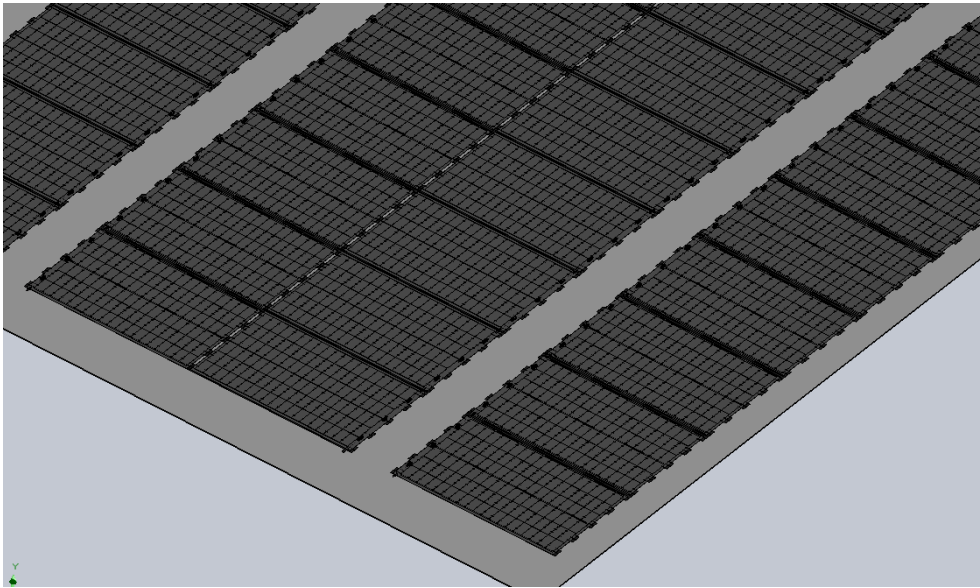

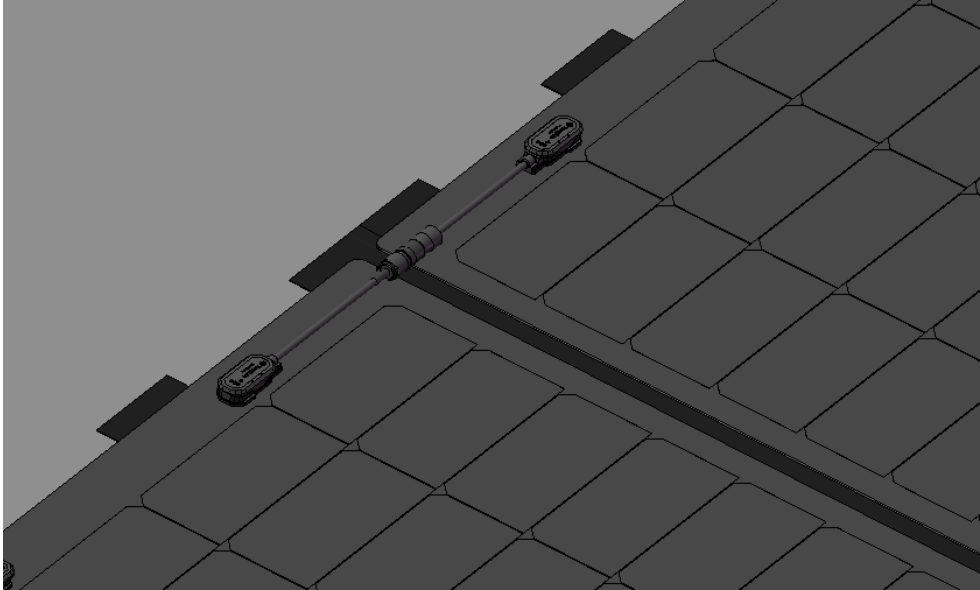

#### 6.5.4 Installation method of laying directly along the roof (paste horizontally)

- Clean the installation roof, without particles, dust and other residues;

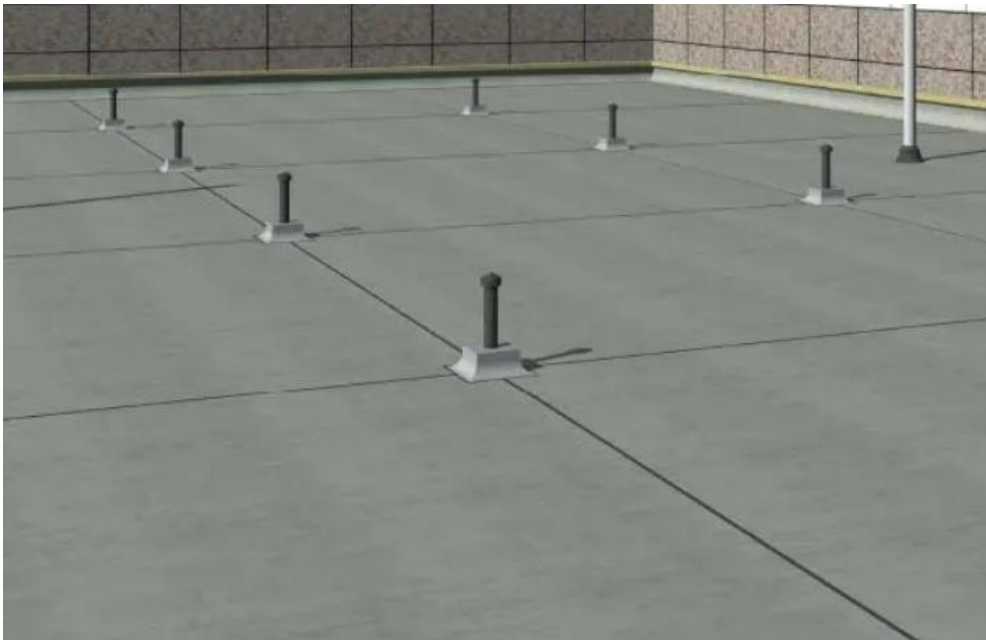

- For cement roofs, the surface is easy to powder, and it is necessary to apply primer on the roof surface first to increase adhesion. First, draw the primer marking line on the roof Interval 302mm, the length is the same as the width of the modules used);

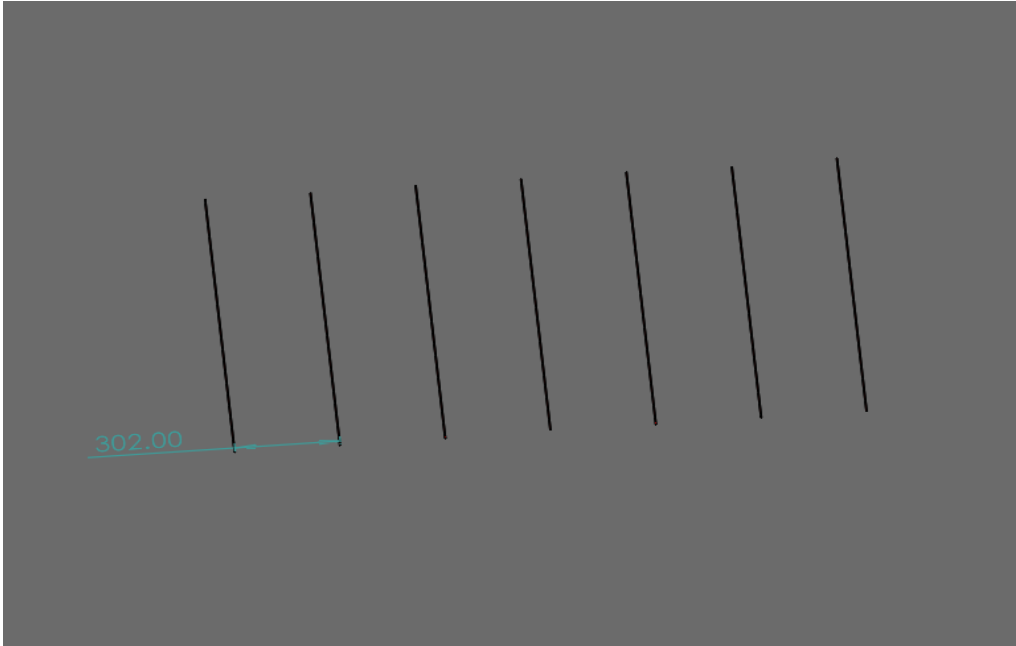

- Brush the primer according to the position of the marking line (if the roof does not need to be brushed with primer, this step can be removed), the width of the primer is not less than 100mm, and wait for the primer to completely cure;

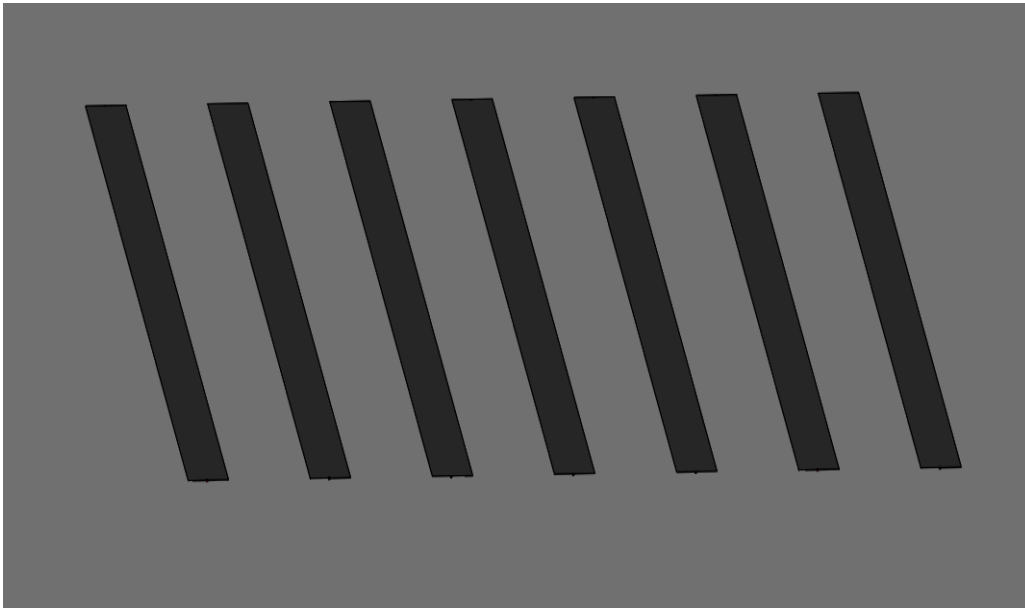

- Paste double-sided tapes on the edge of module;

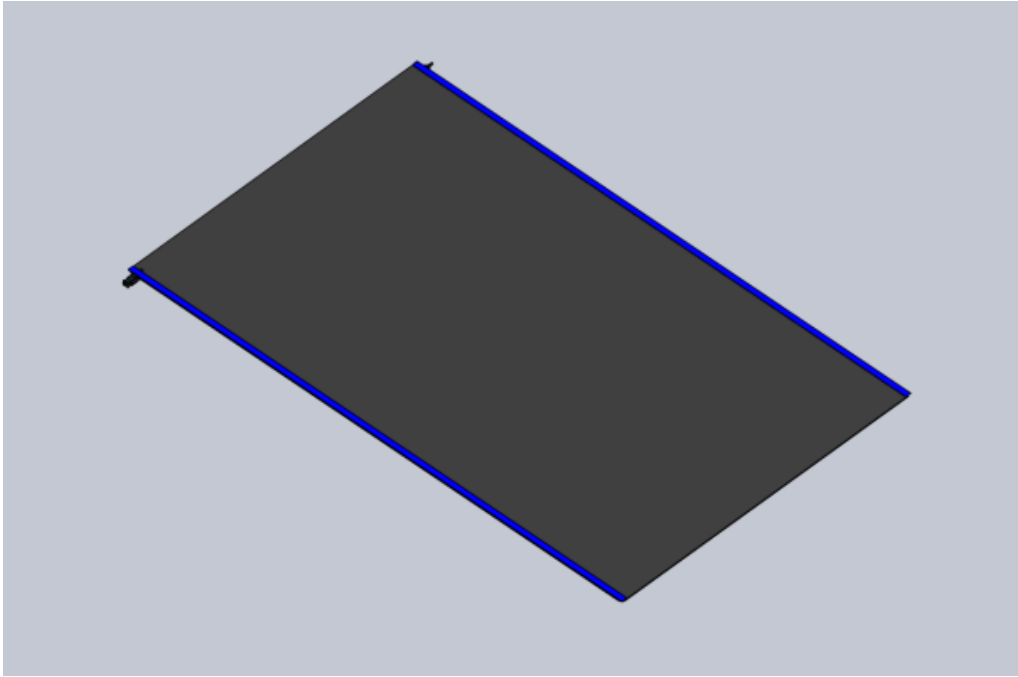

- Gluing on the primer after it curing;

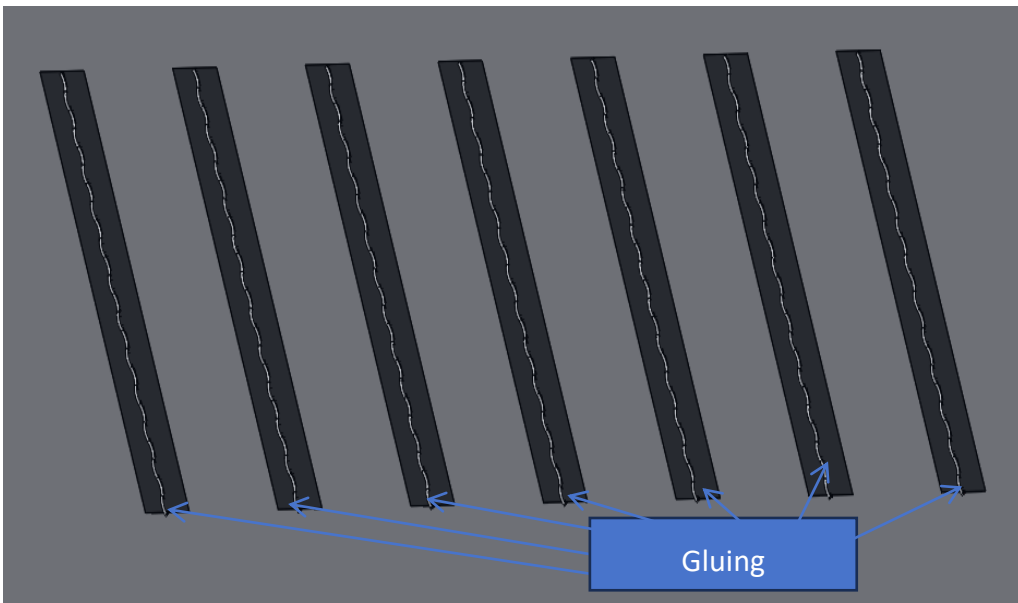

- Install solar module, press carefully by tooling for the gluing parts;

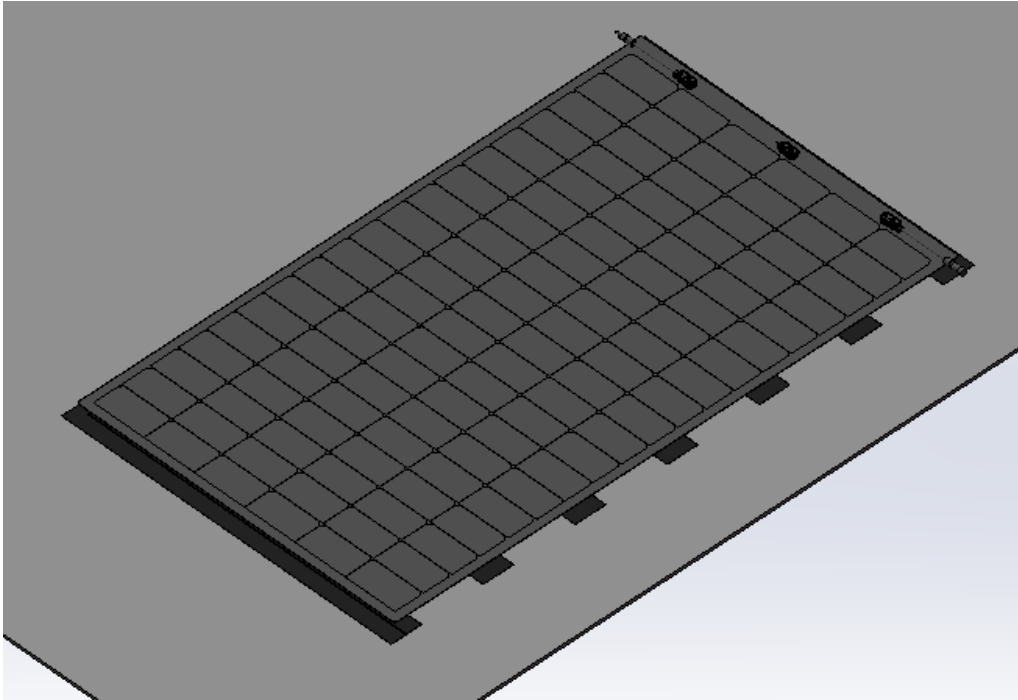

- Repeat the above operation to install other PV modules according to the layout, and connect the positive and negative connectors.

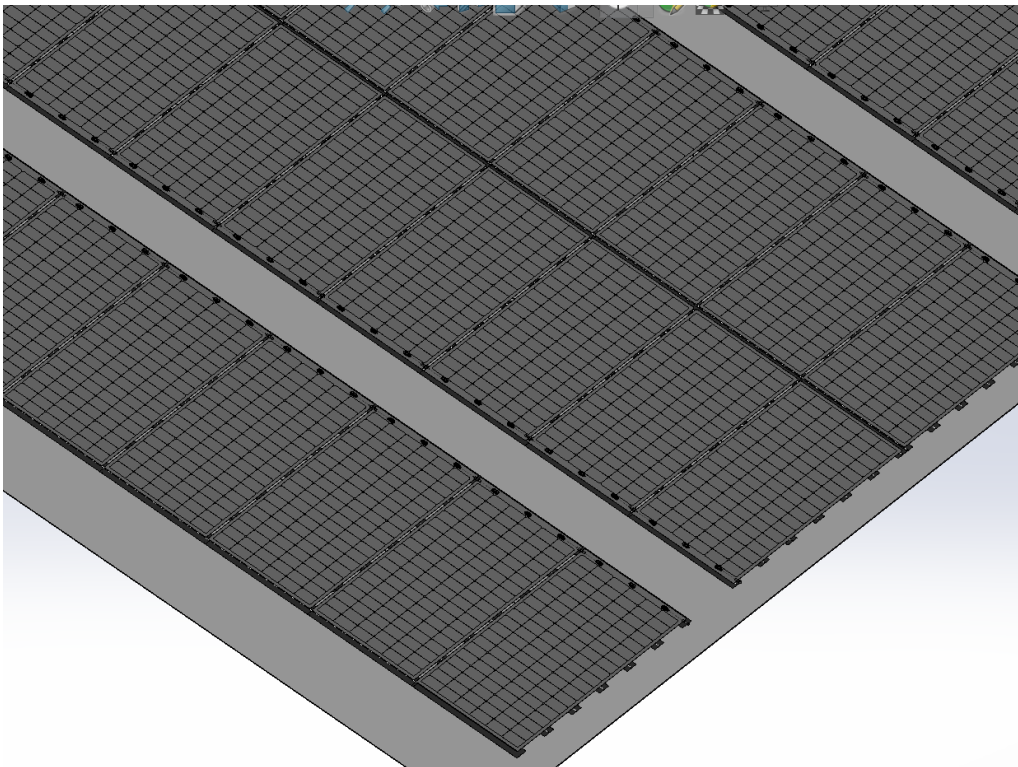

## 6.6 Metal roof construction scheme

Color steel tile roofs are the most typical and common metal roofs. This

installation method is suitable for trapezoidal color steel tiles, which are installed using direct paste or square tubes.

**Cushion square pipe:**

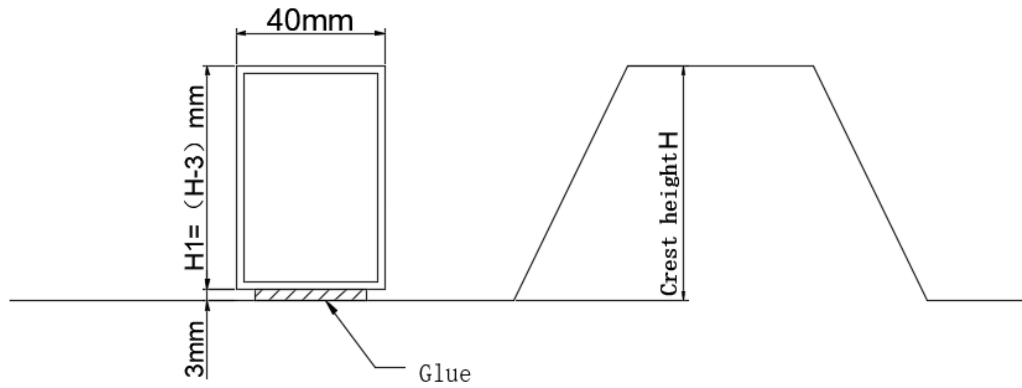

Size: Width 40mm,  $H1=(H-3\text{mm})\pm 2\text{mm}$ , the same length as the module;

**6.6.1 Trapezoidal color steel tile roof installation method 1**

It is suitable for crest spacing  $\leq 274\text{mm}$  color steel tiles.



- Clean the surface, it needs to be free from particles, dust and other residues. The specified or approved cleaning agents may be used to clean the roof substrate. If the roof substrate is excessively dirty, it should first be rinsed with low-pressure water or a power washer before using a cleaning solution of (1/4 cup of trisodium phosphate, 1/2 cup of liquid detergent (optional), and 5 gallons of water);



- Use a glue gun to apply adhesive at the peak of the color steel tile; the length of

the structural adhesive should be equal to the length of the module, and if the overhanging part of the modules exceeds 50mm, use a square tube as a spacer.

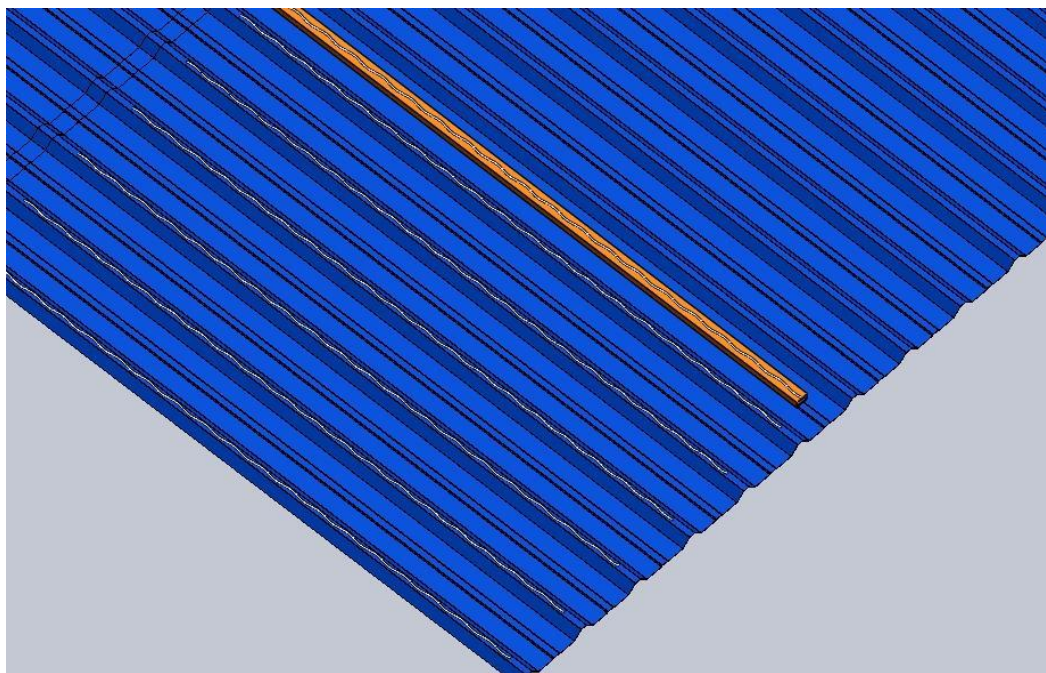
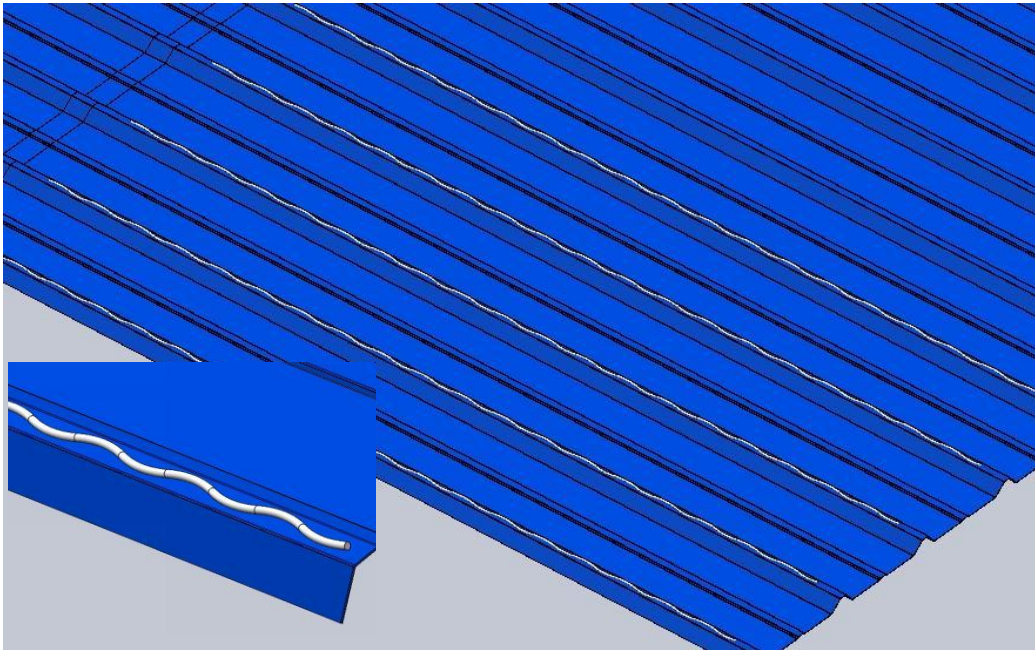

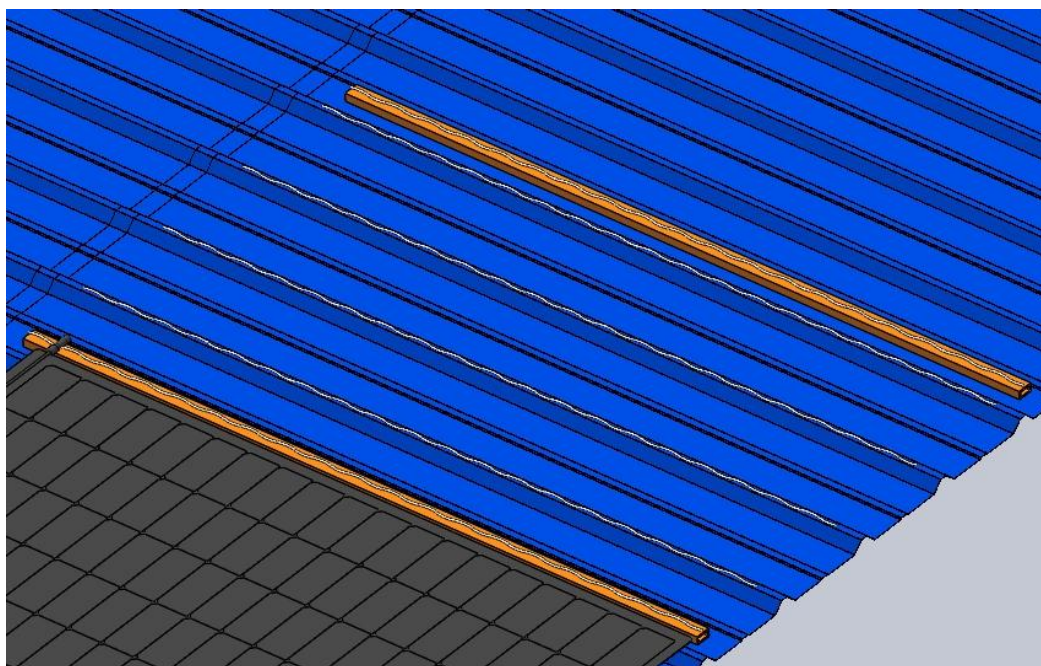

- When installing photovoltaic modules, use a brush tool to carefully press on the silicone adhesive areas of the module. Do not use your hands to press down on the solar cells for stability;

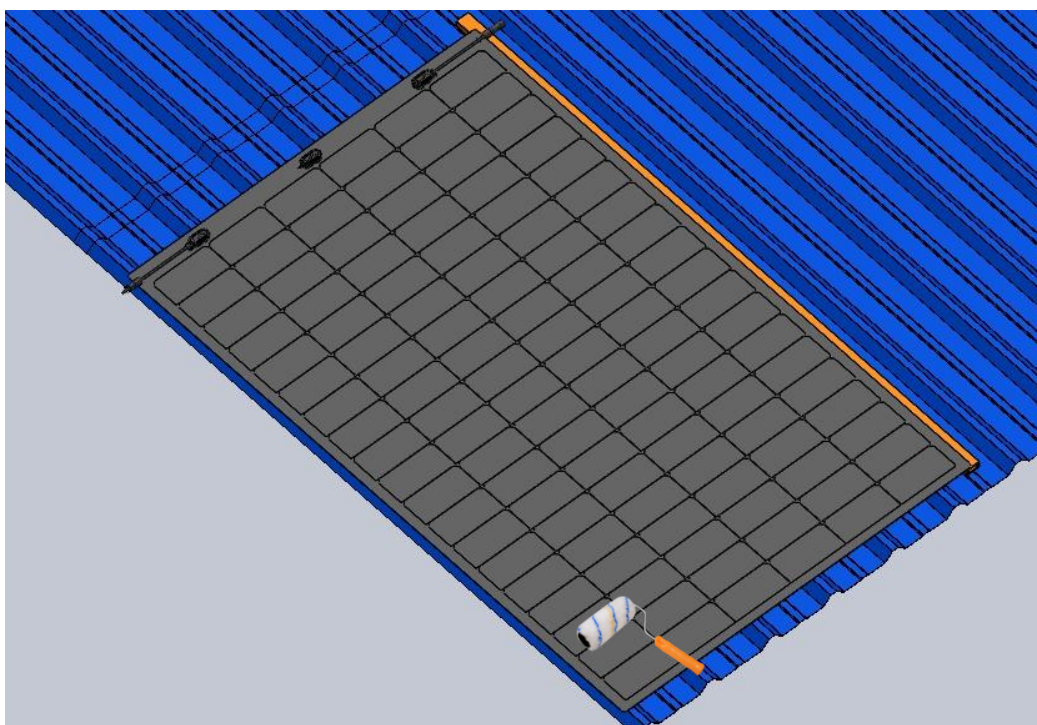

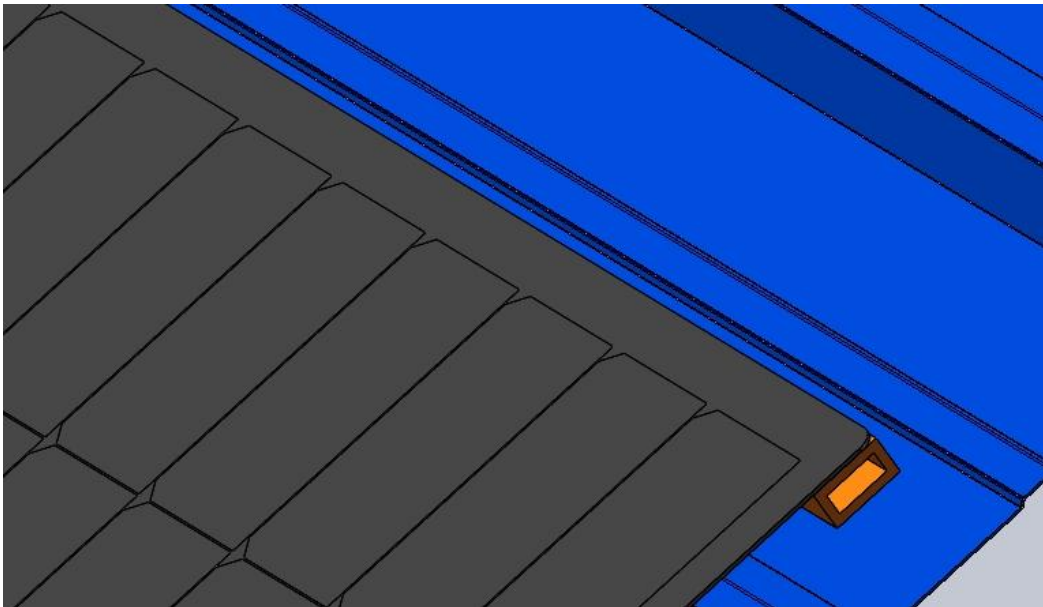
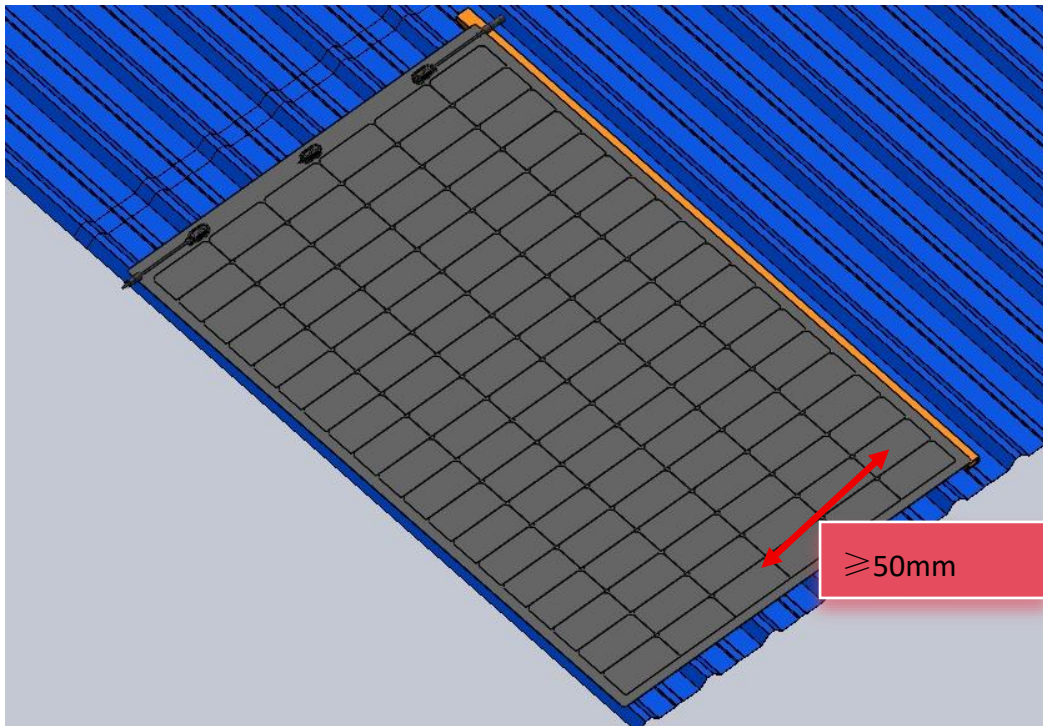

- If there are joint conditions from the ridge of the color steel tile to the eaves, the seams must be positioned between the modules. A single module must not cover the seams;

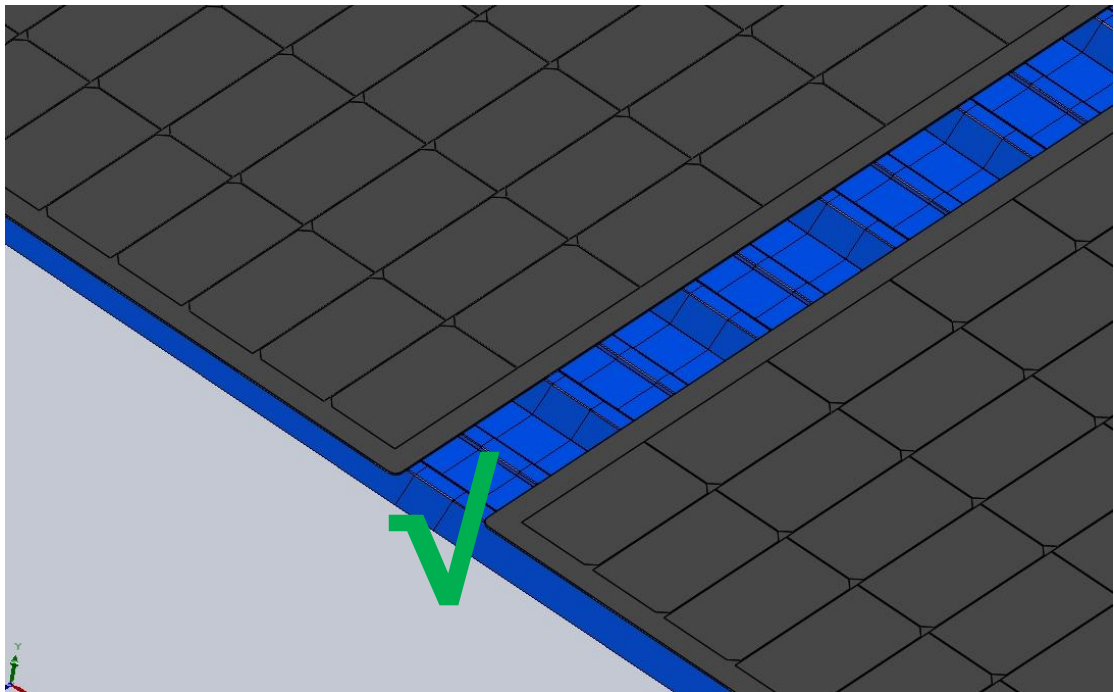
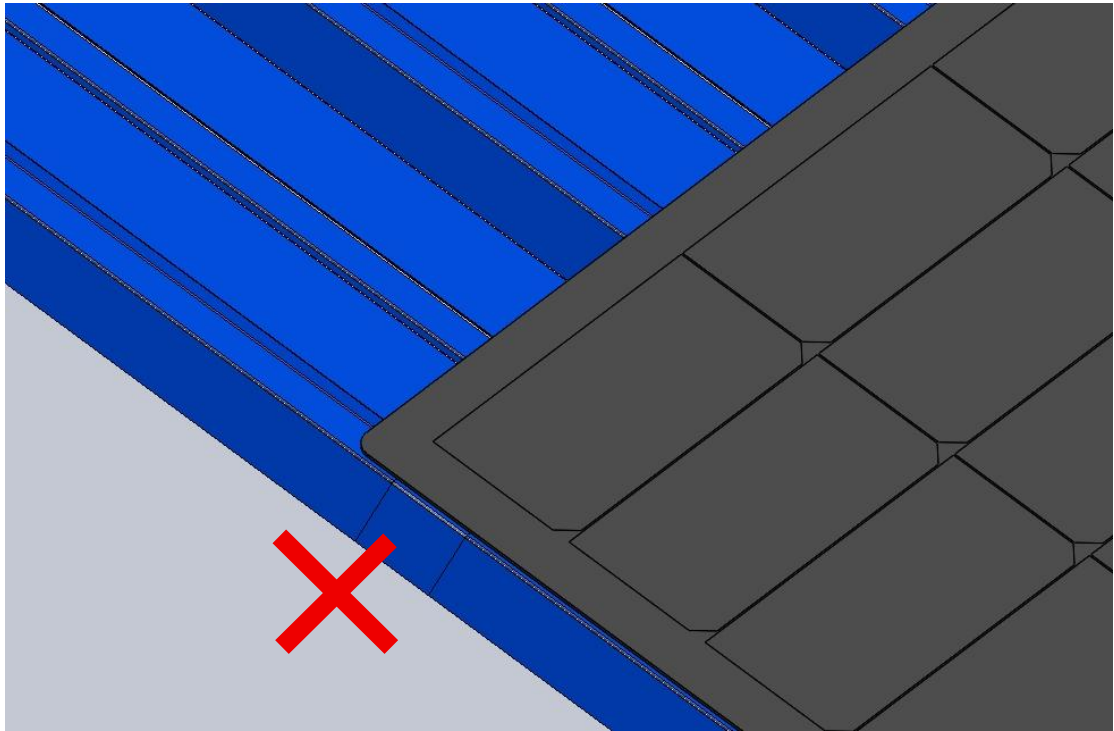

- Install other solar modules by layout and connect the positive and negative connectors.

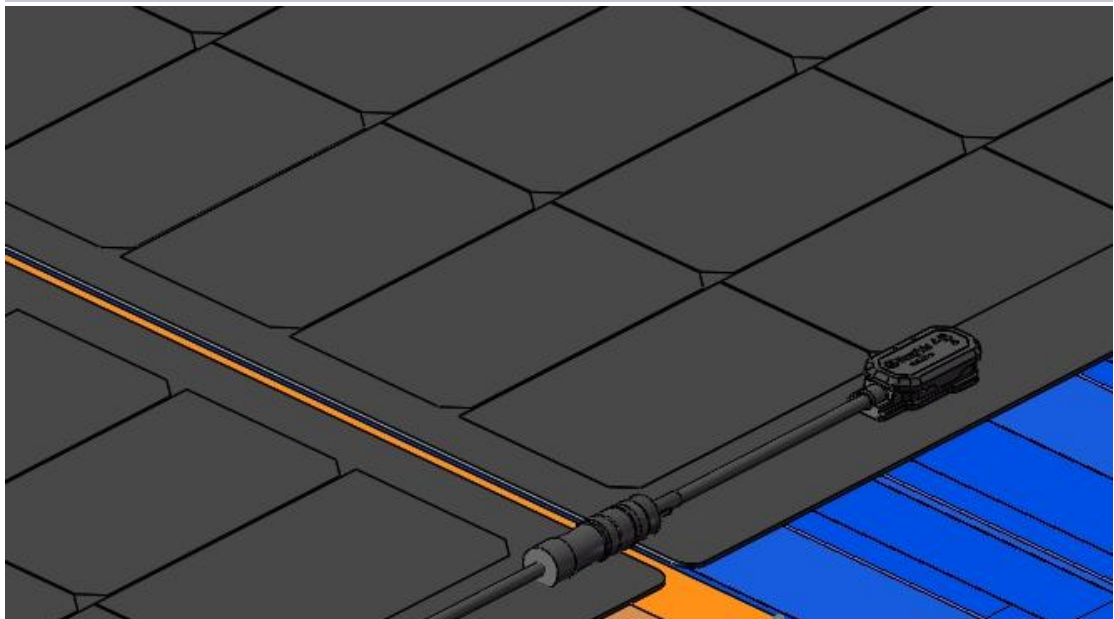
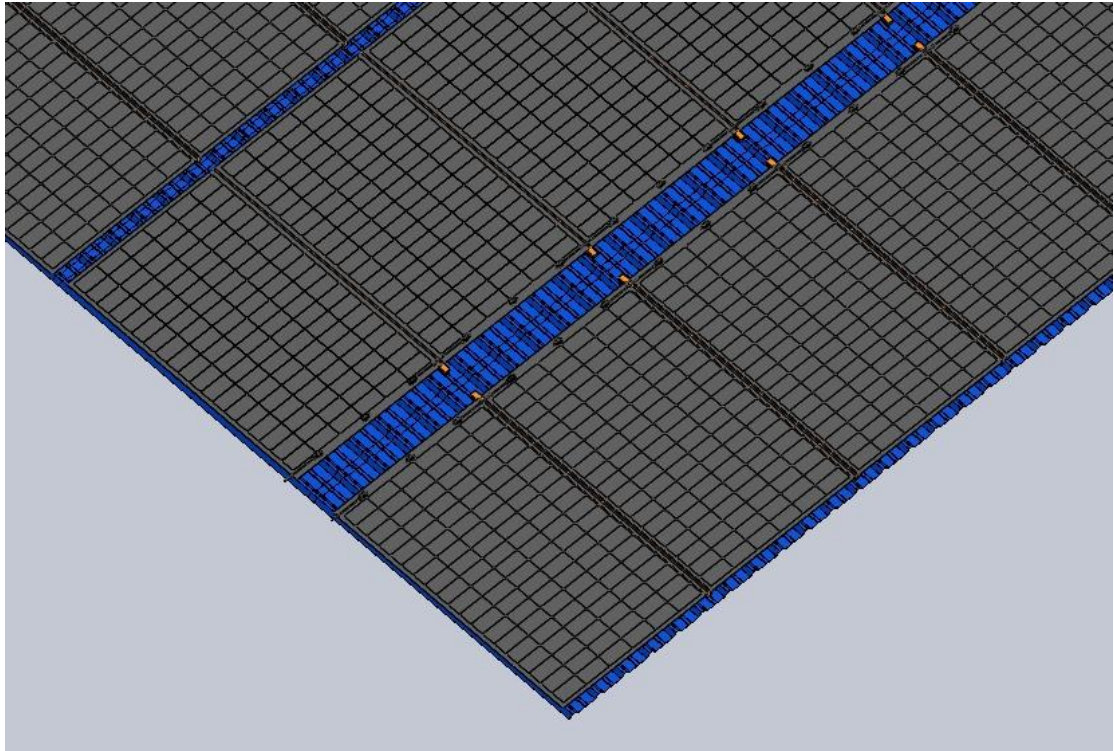

- The minimum distance between modules is 20mm, with a maintenance passage of 500 to 800mm between arrays (this spacing is for reference only); adjacent modules shall share leveling aluminum strips; junction boxes should be placed on the side of the maintenance passage to facilitate string connections and inspections.

## 6.6.2 Trapezoidal color steel tile roof installation method 2

It is suitable for crest spacing  $> 274\text{mm}$  color steel tiles.

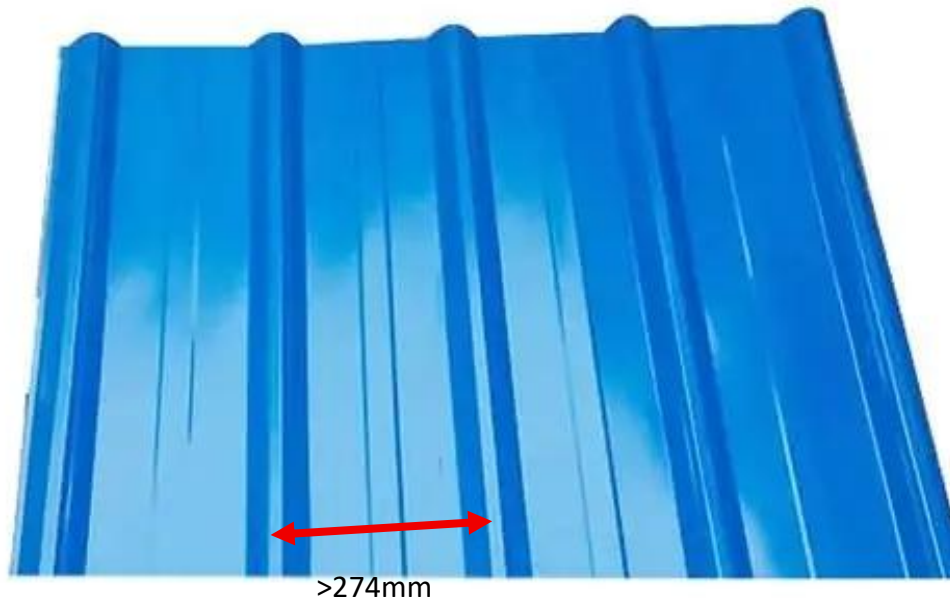

- Cleaning the wall, without particles, dust and other residues. The specified or approved cleaning agents (see Appendix C) may be used to clean the roof substrate. If the roof substrate is excessively dirty, it should first be rinsed with low-pressure water or a power washer before using a cleaning solution of (1/4 cup of trisodium phosphate, 1/2 cup of liquid detergent (optional), and 5 gallons of water);



- Use silicone to glue in the middle position of the color steel tile valley, and bond the square pipe to the middle position of the color steel tile valley;

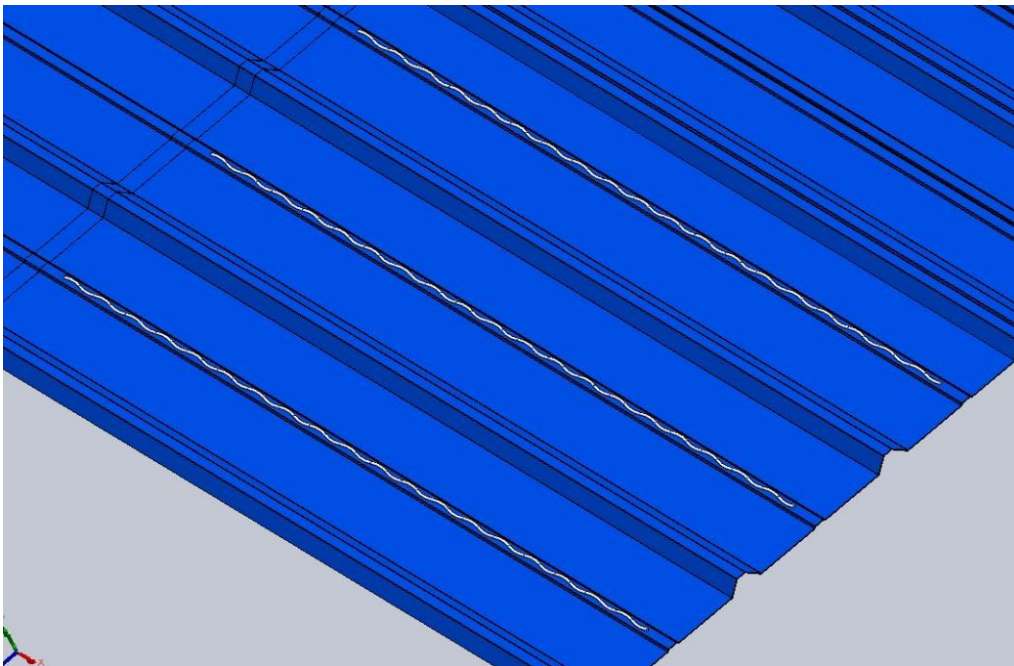

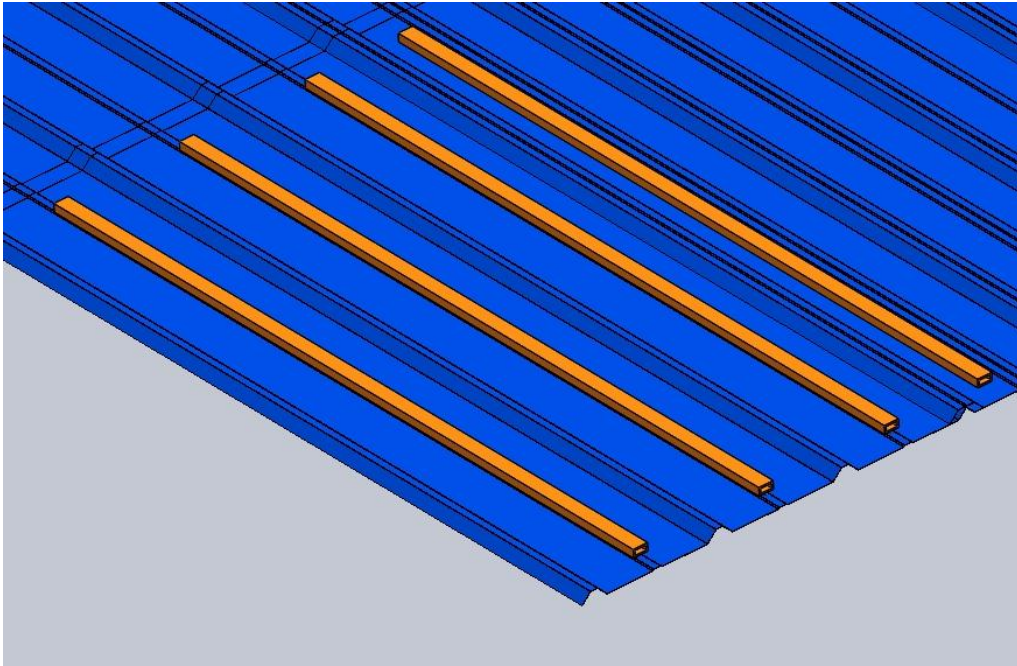

- Glue at the square pipe and color steel tile peak crown respectively, and the length of the structural glue is equal to the width of the module. A flat square tube should be used for the cantilever portion of modules greater than 50mm;

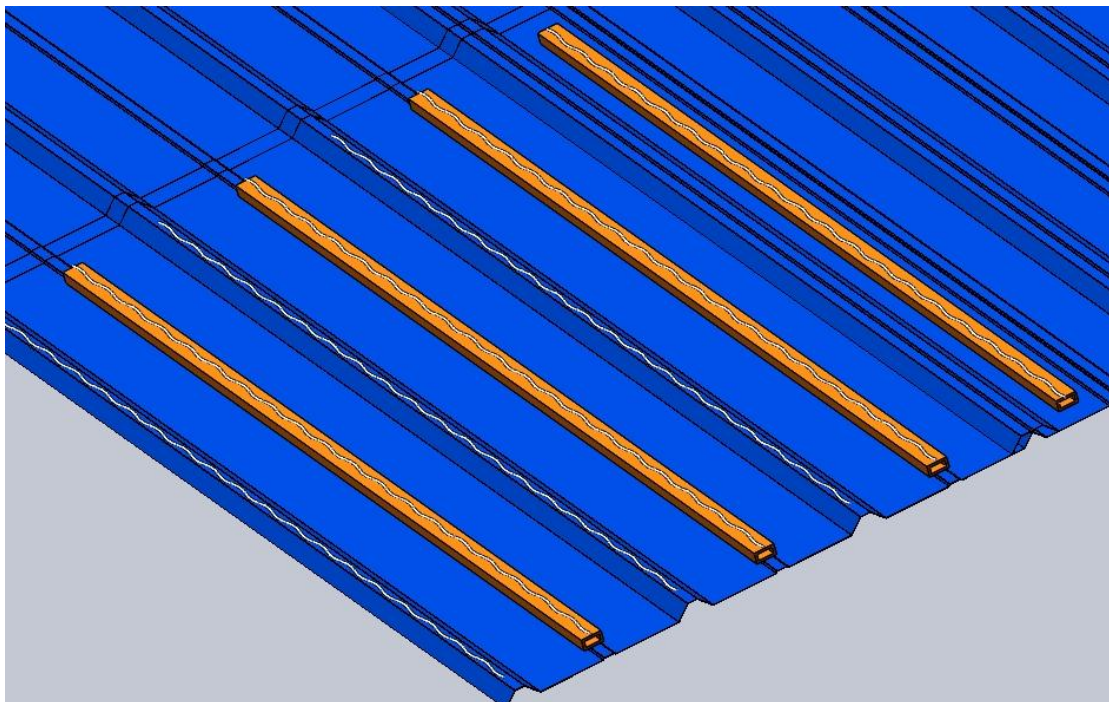

- When installing photovoltaic modules, use a brush tool to carefully press on the silicone adhesive areas of the module. Do not use your hands to press down on the solar cells for stability;

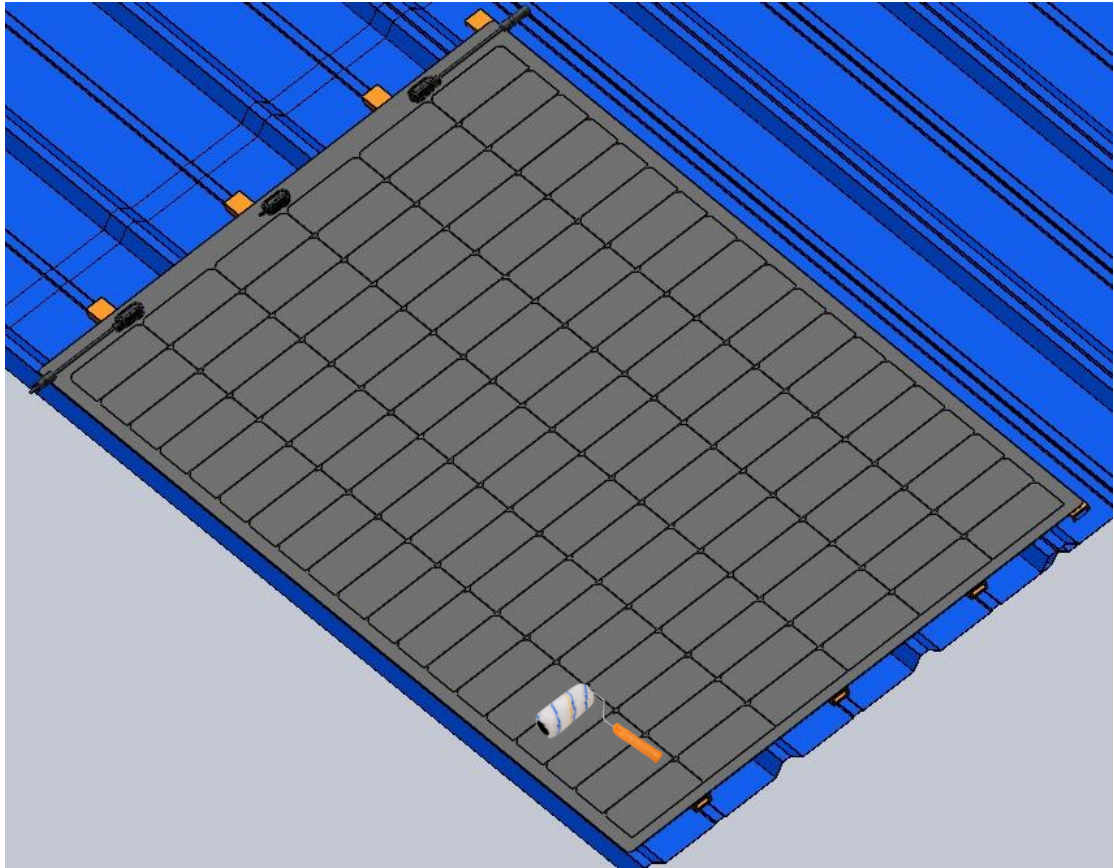

- If there is a splicing situation from the ridge to the eaves of the color steel tiles, the seams must be placed between the modules. Individual modules should not overlap the seams;

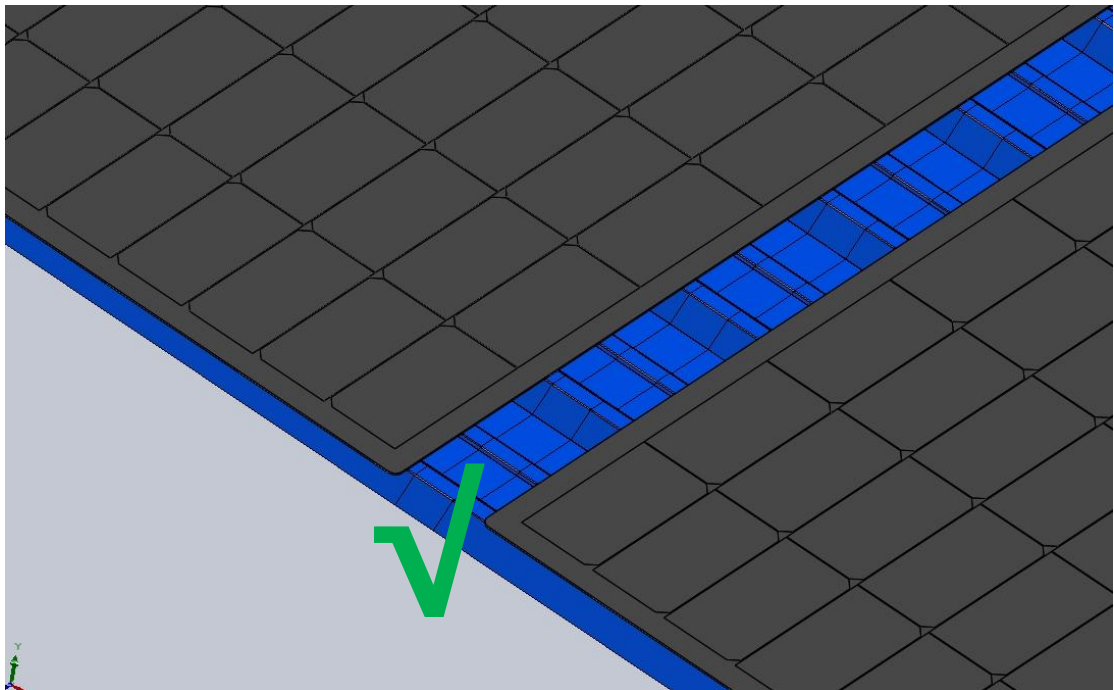

- Install other solar modules by layout and connect the positive and negative connectors.

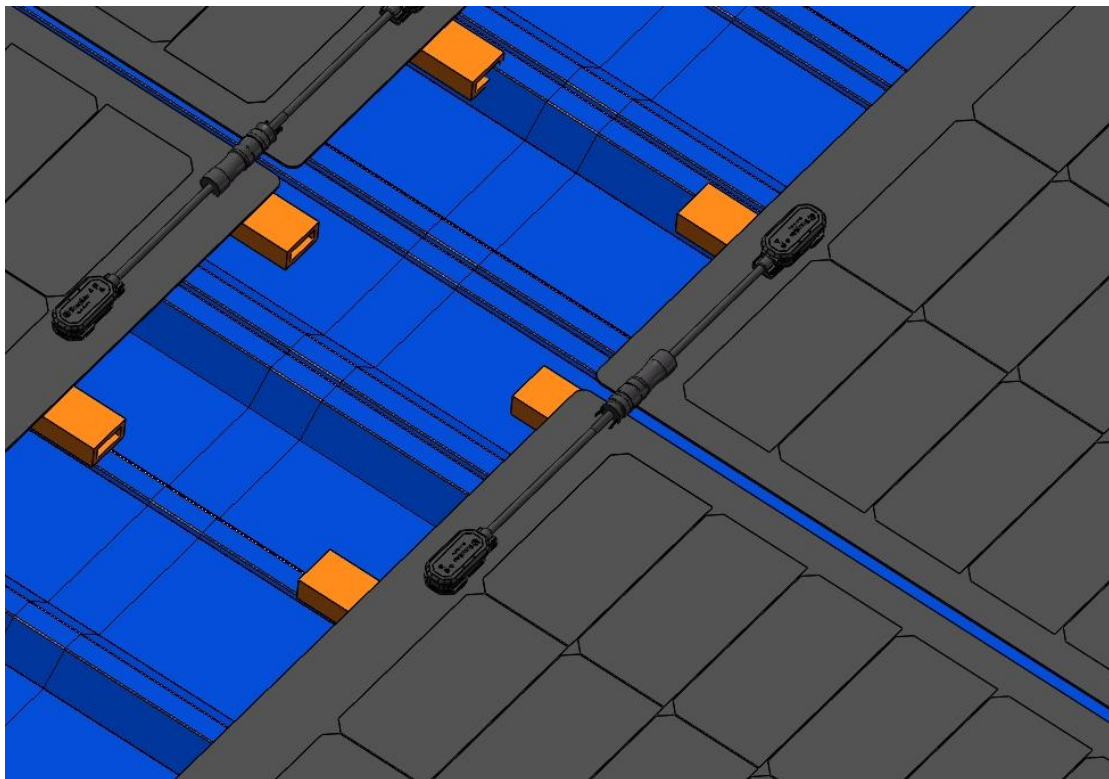
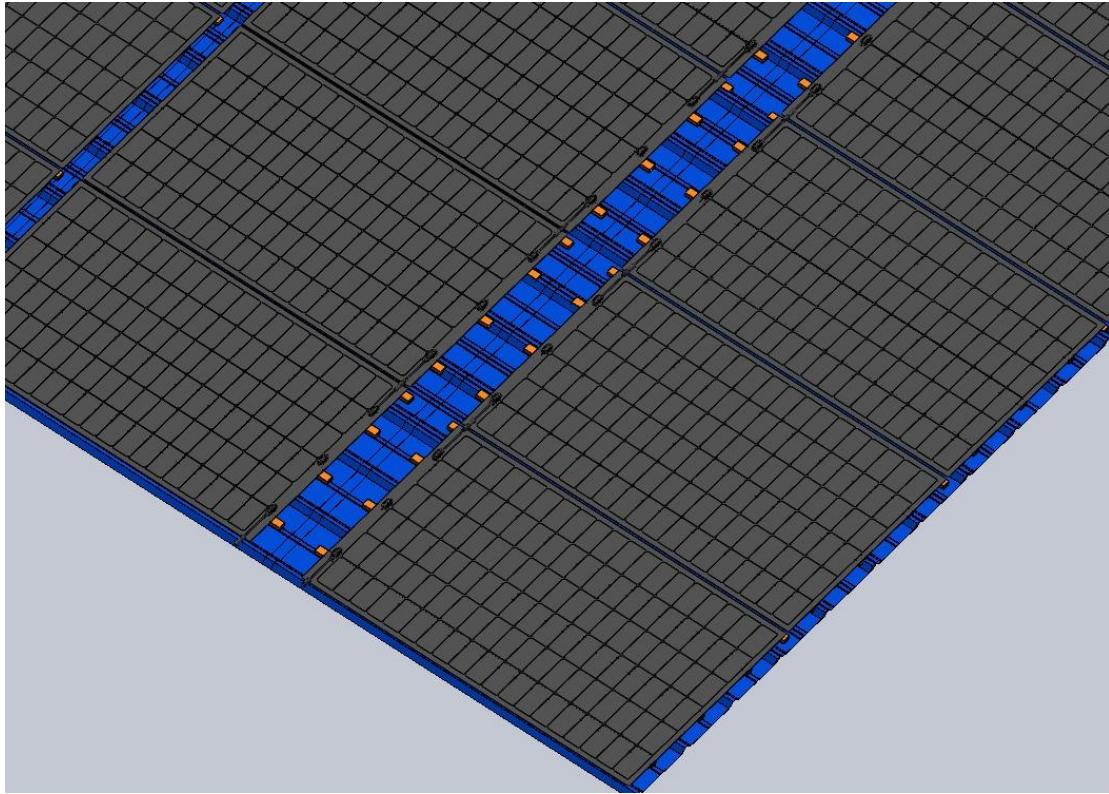

- The minimum distance between modules is 5mm, and the construction and maintenance channel between arrays is 500~800mm (this spacing is for reference

only); Adjacent modules share a cushion square tube; Place the junction box on the side of the access channel to facilitate serial wiring and maintenance inspection.

### 6.6.3 Trapezoidal color steel tile roof installation method 3

It is suitable for crest spacing  $\leq 302\text{mm}$  color steel tiles.



- Cleaning the wall, without particles, dust and other residues. The specified or approved cleaning agents (see Appendix C) may be used to clean the roof substrate. If the roof substrate is excessively dirty, it should first be rinsed with low-pressure water or a power washer before using a cleaning solution of (1/4 cup of trisodium phosphate, 1/2 cup of liquid detergent (optional), and 5 gallons of water);



- Use a glue gun to glue the color steel tile peak crown; The length of the structural adhesive is equal to the width of the module, If the cantilever part of the module > 50mm, use cushion square pipe;

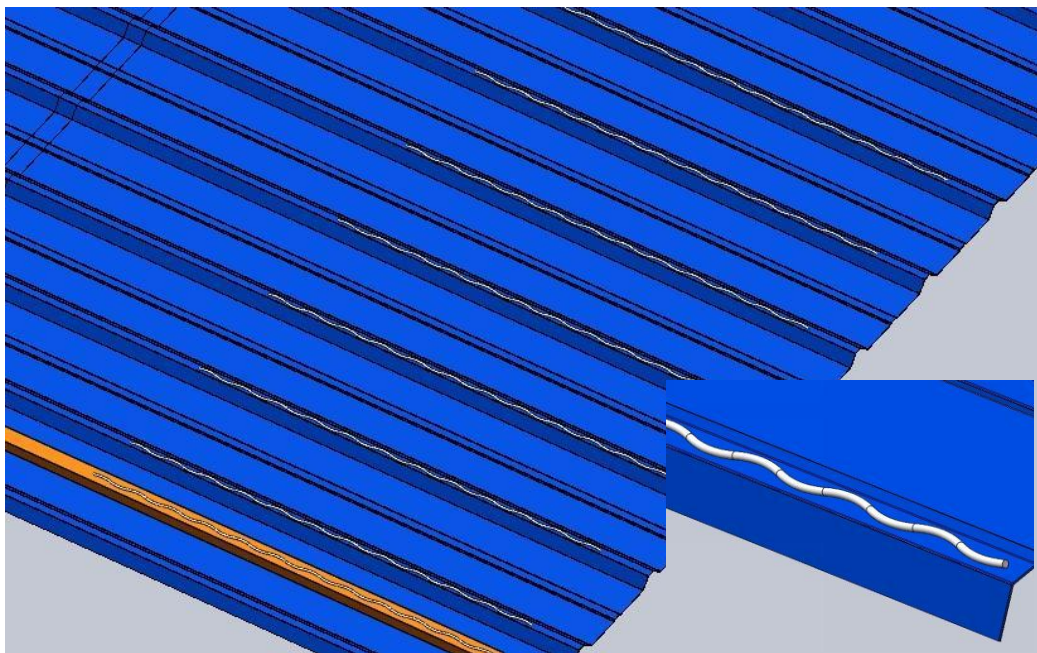

- Install photovoltaic modules, use a brush tool to carefully press the silicone gluing position of the modules, and do not press the cells with your hands for stability; The junction box should be placed at the crest of the color steel plate;

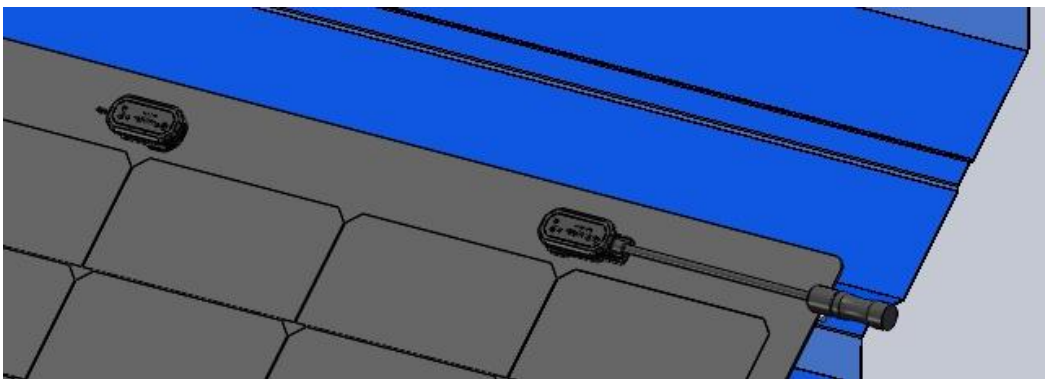
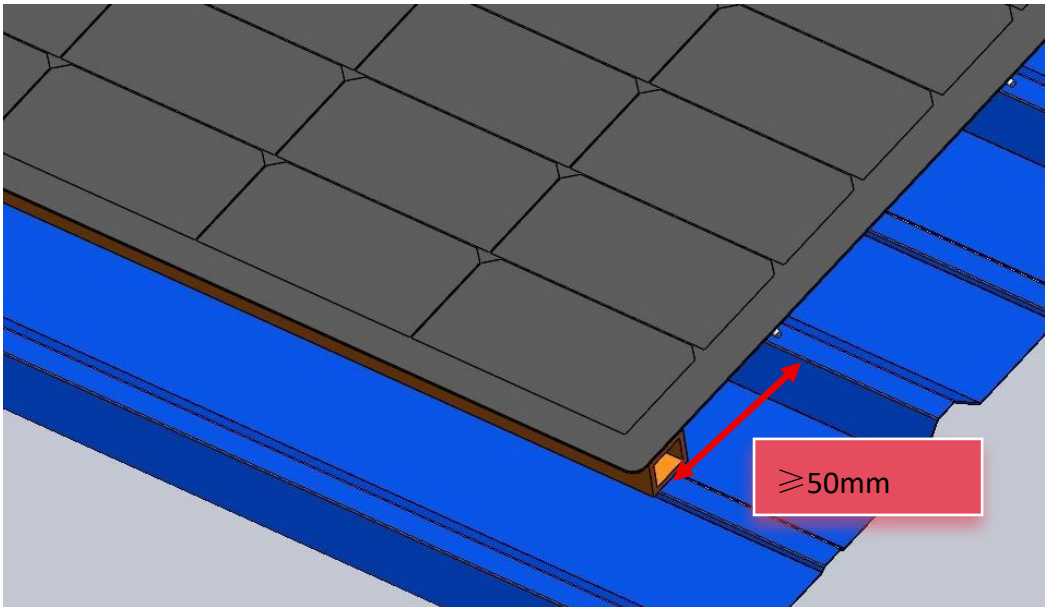
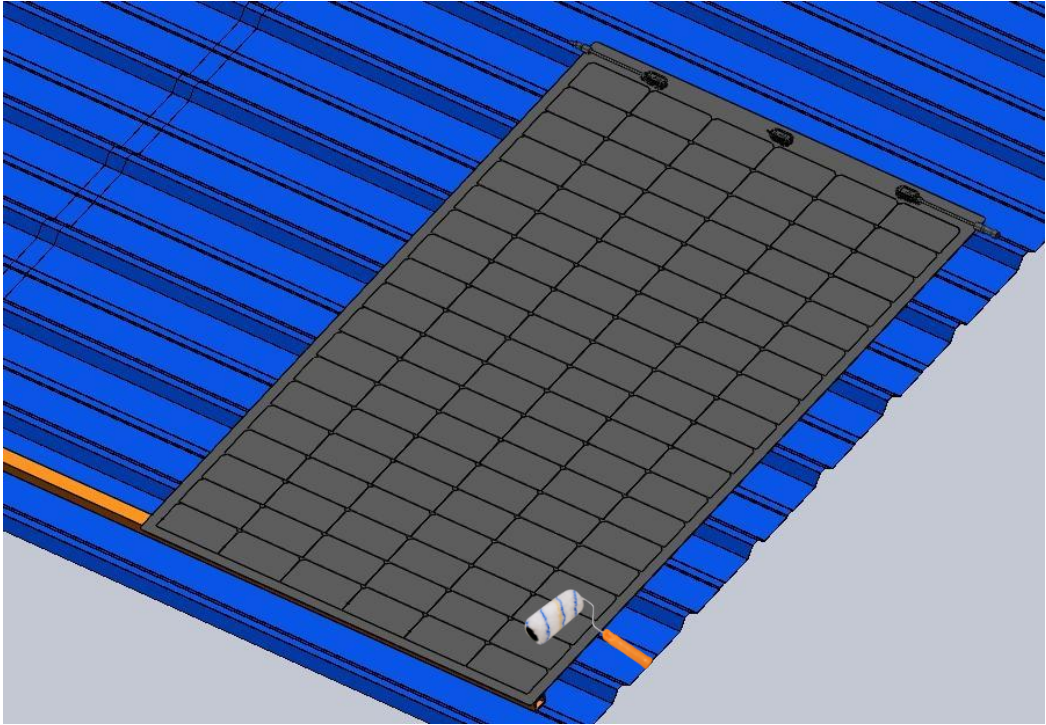

- If there are joint conditions from the ridge of the color steel tile to the eaves, the seams must be positioned between the modules. A single module must not cover the seams;

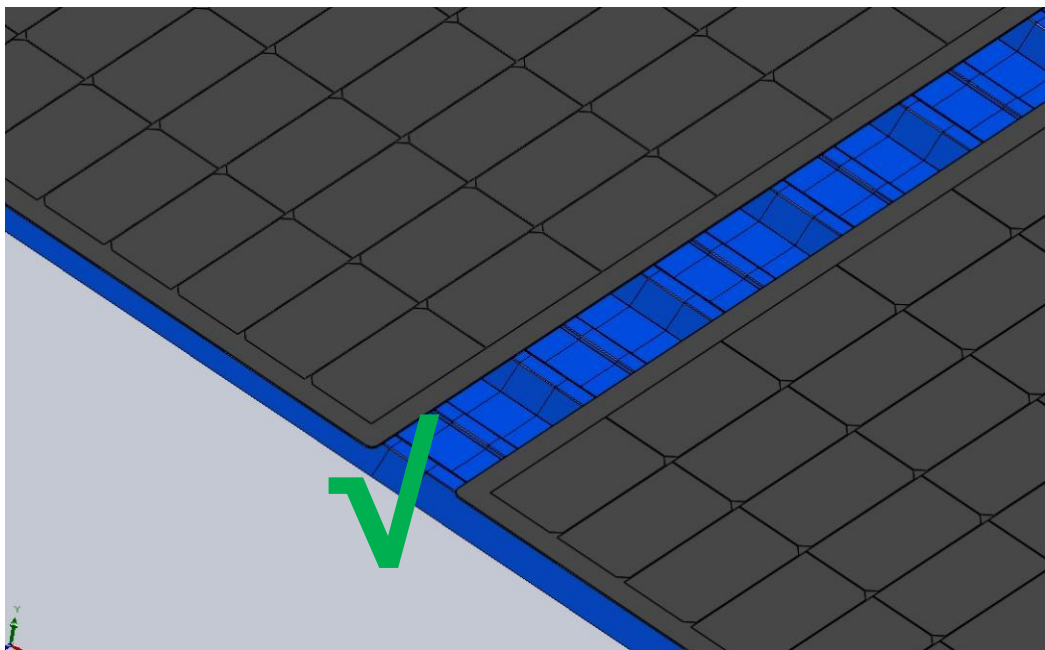
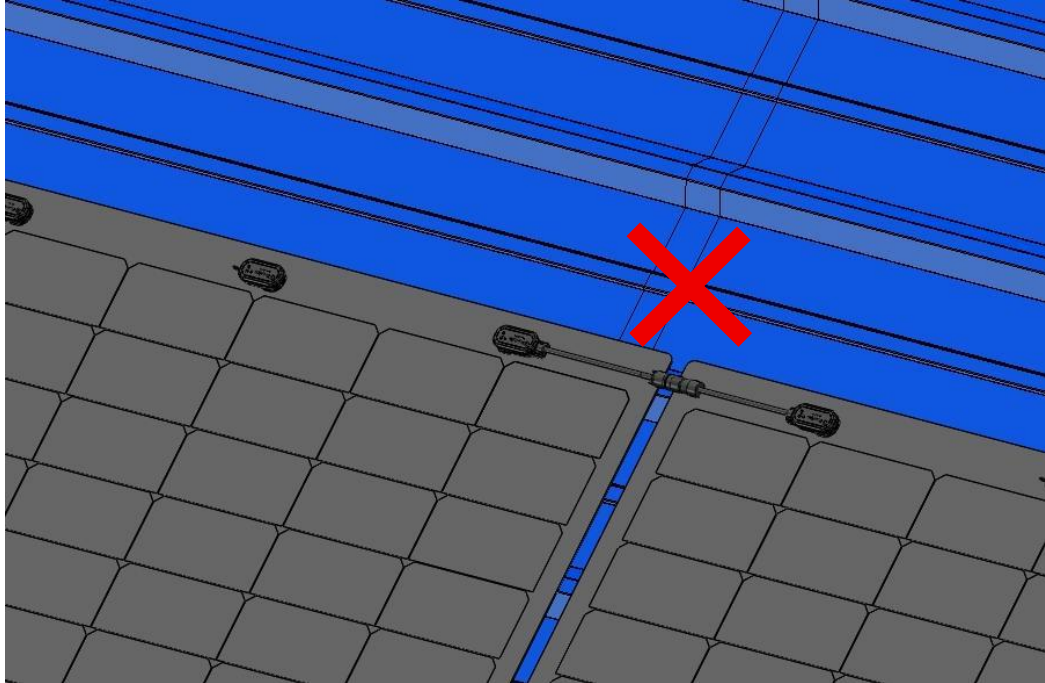

- If there is splicing of the cushion square pipe, the splicing must be between the modules. A single module cannot be covered with aluminum square pipe seams;

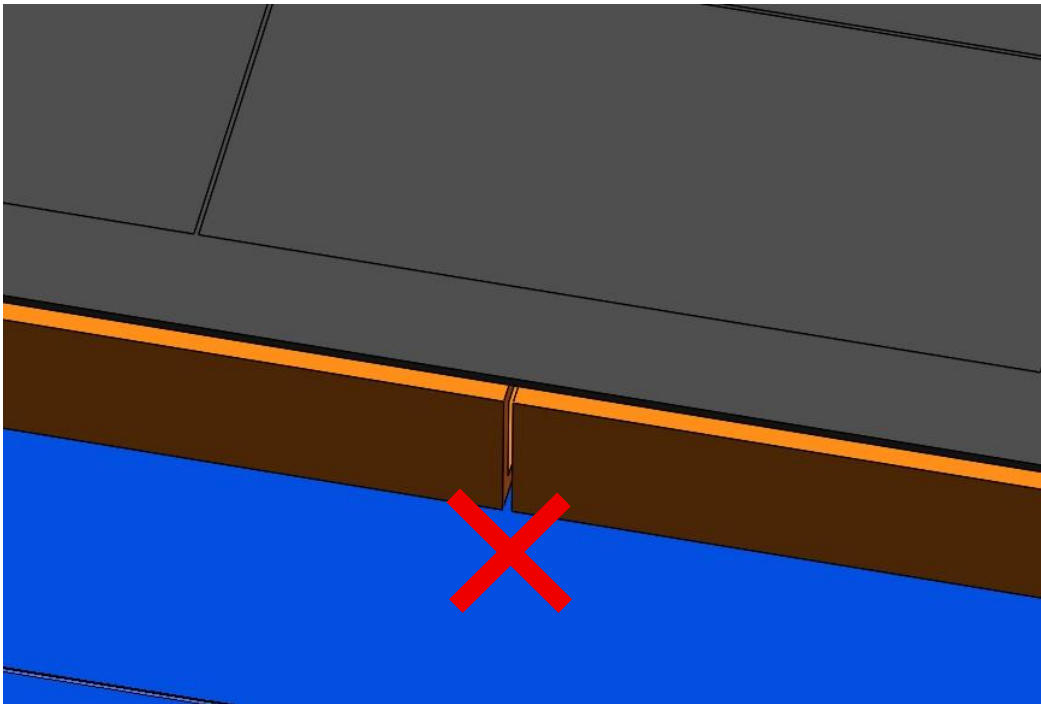
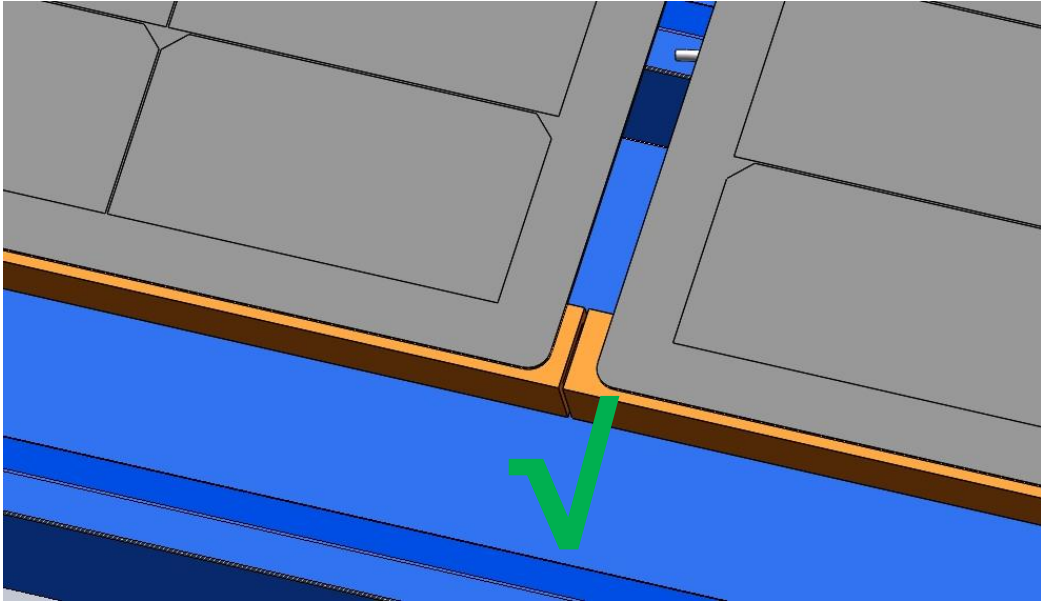

- Install other solar modules by layout and connect the positive and negative connectors;

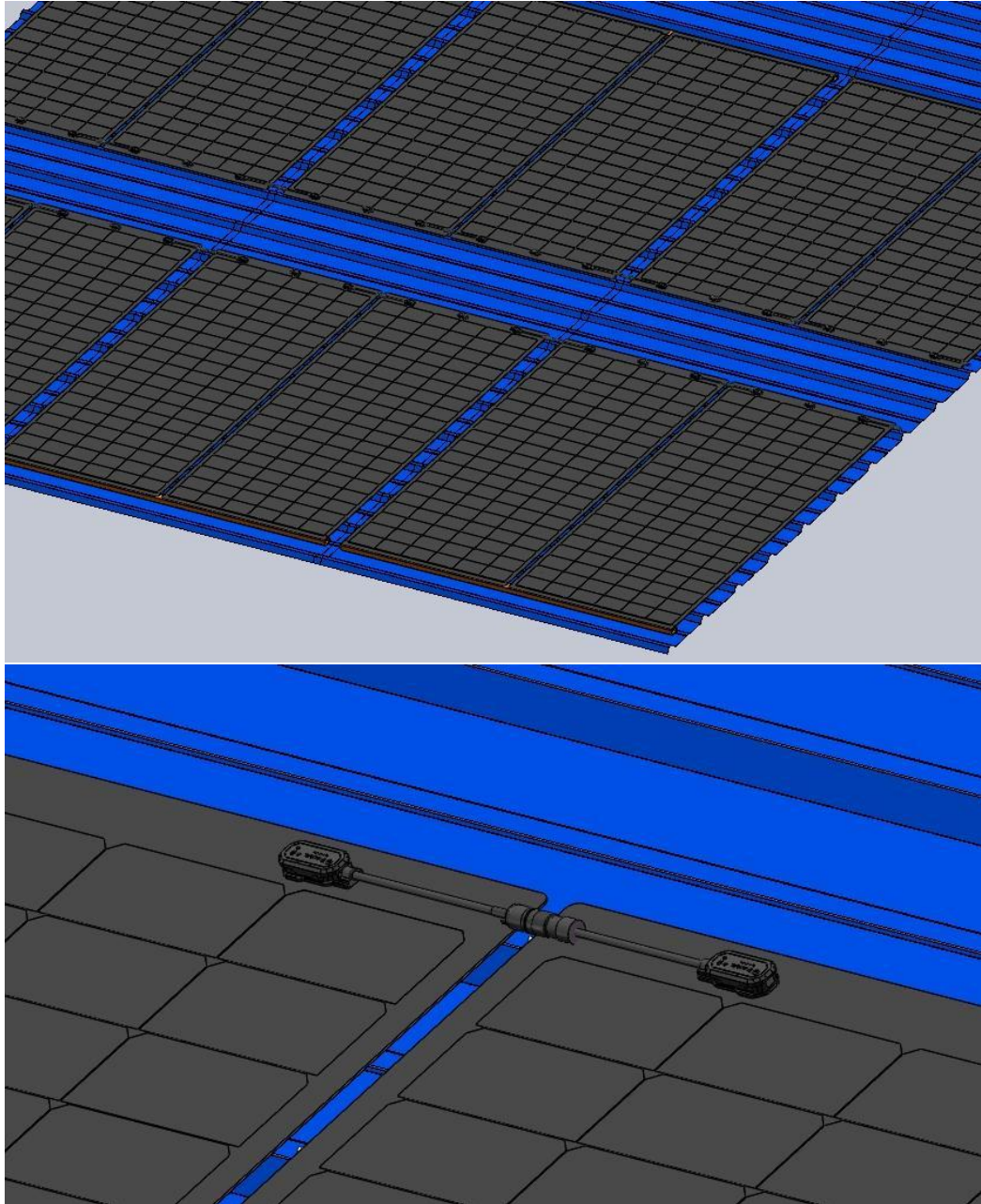

- The minimum distance between modules is 20mm, with a maintenance passage of 500 to 800mm between arrays (this spacing is for reference only); adjacent modules shall share leveling aluminum strips; junction boxes should be placed on the side of the maintenance passage to facilitate string connections and inspections.

#### **6.6.4 Trapezoidal color steel tile roof installation method 4**

It is suitable for crest spacing  $> 302$ mm color steel tiles.

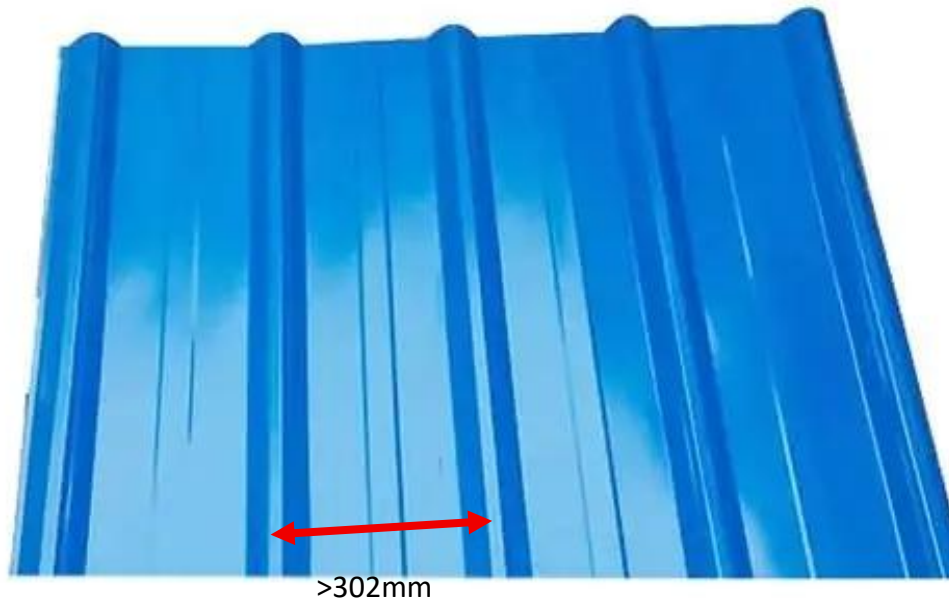

- Cleaning the wall, without particles, dust and other residues. The specified or approved cleaning agents (see Appendix C) may be used to clean the roof substrate. If the roof substrate is excessively dirty, it should first be rinsed with low-pressure water or a power washer before using a cleaning solution of (1/4 cup of trisodium phosphate, 1/2 cup of liquid detergent (optional), and 5 gallons of water);



- Use silicone to glue in the middle position of the color steel tile valley, and bond the square pipe to the middle position of the color steel tile valley;

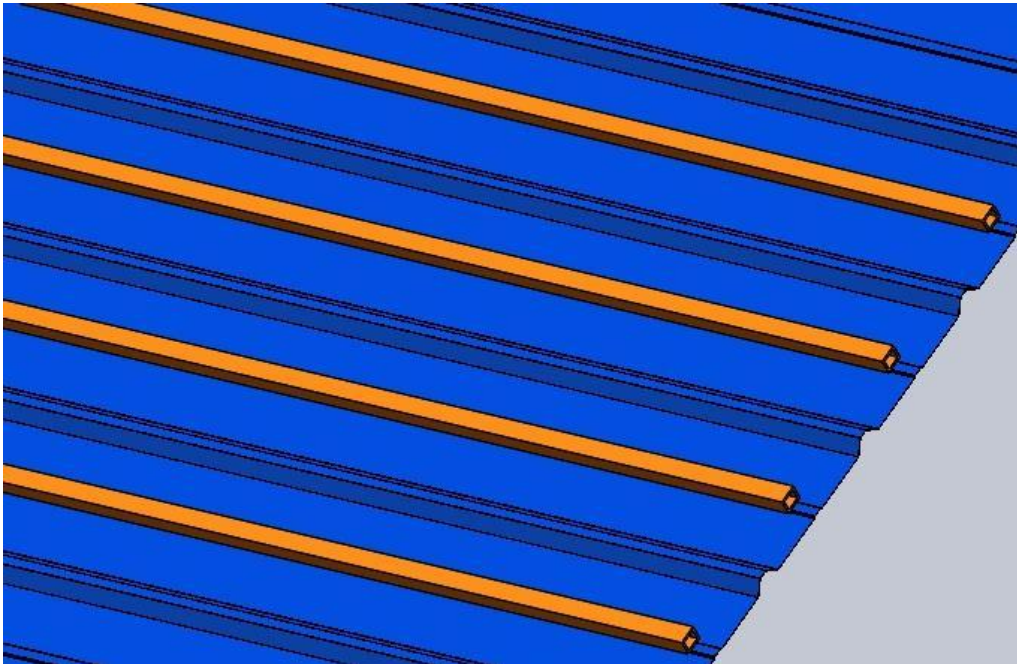
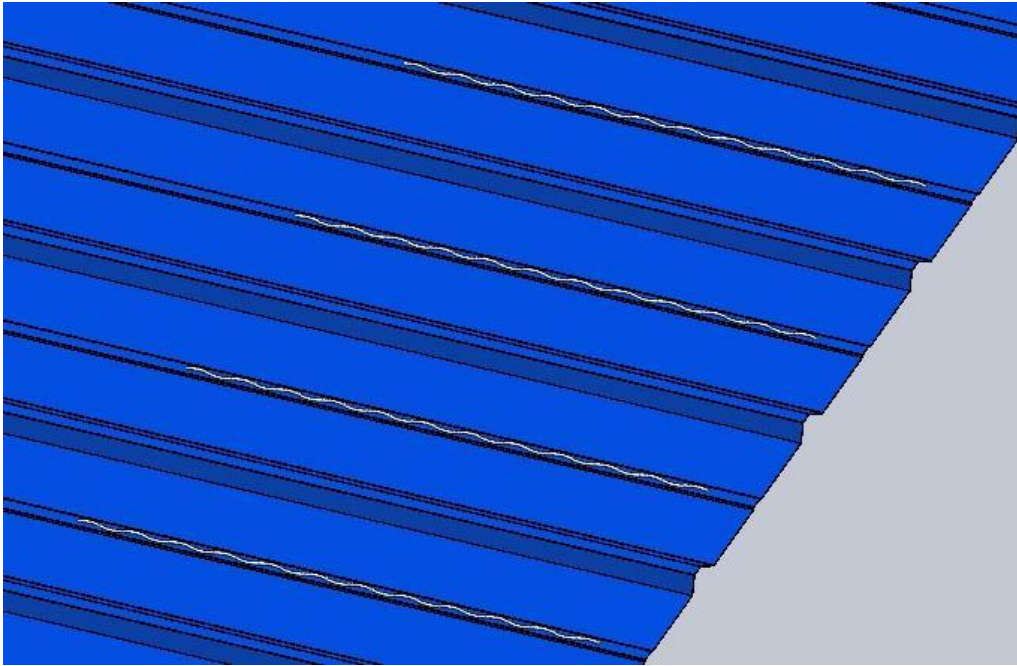

- Glue at the square pipe and color steel tile peak crown respectively, and the length of the structural glue is equal to the width of the module. A flat square tube should be used for the cantilever portion of modules greater than 50mm;

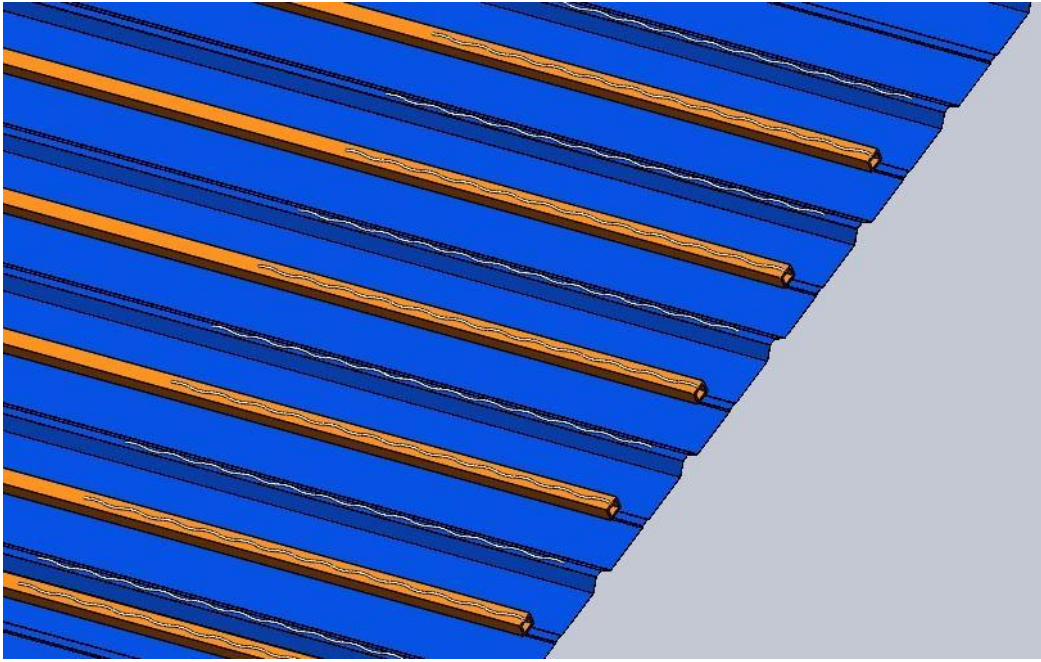

- When installing photovoltaic modules, use a brush tool to carefully press on the silicone adhesive areas of the module. Do not use your hands to press down on the solar cells for stability;

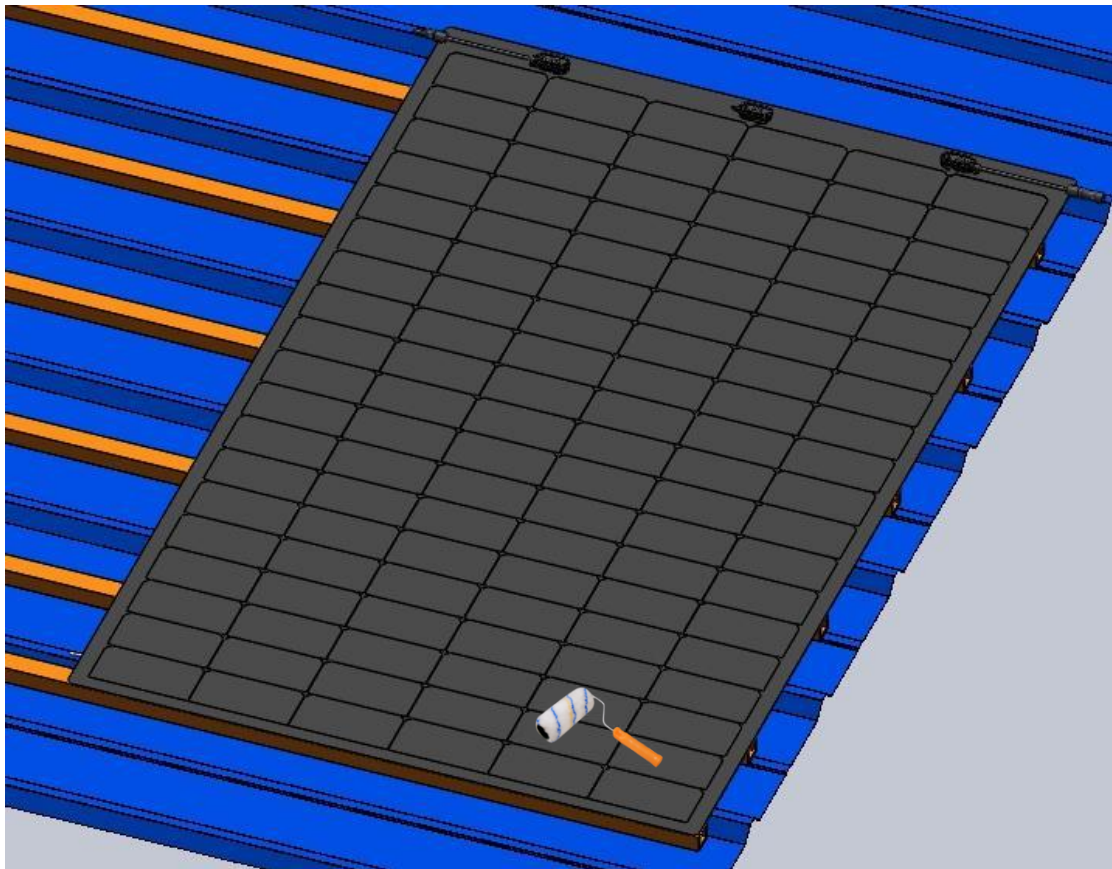

- If there is a splicing situation from the ridge to the eaves of the color steel tiles, the seams must be placed between the modules. Individual modules should not overlap the seams;

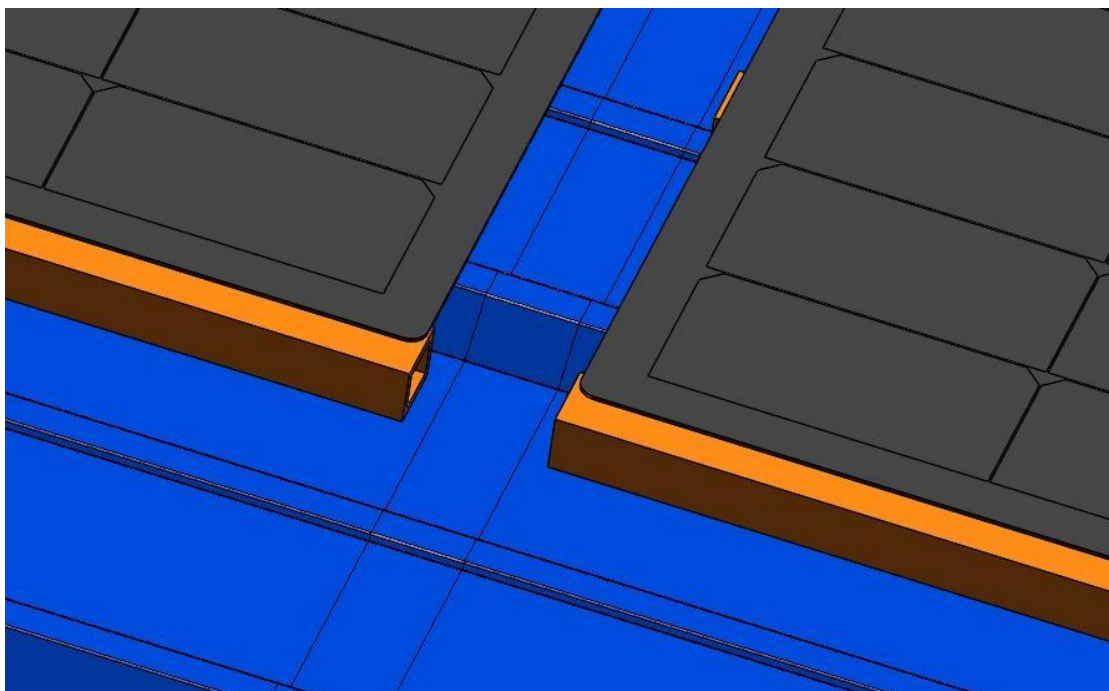
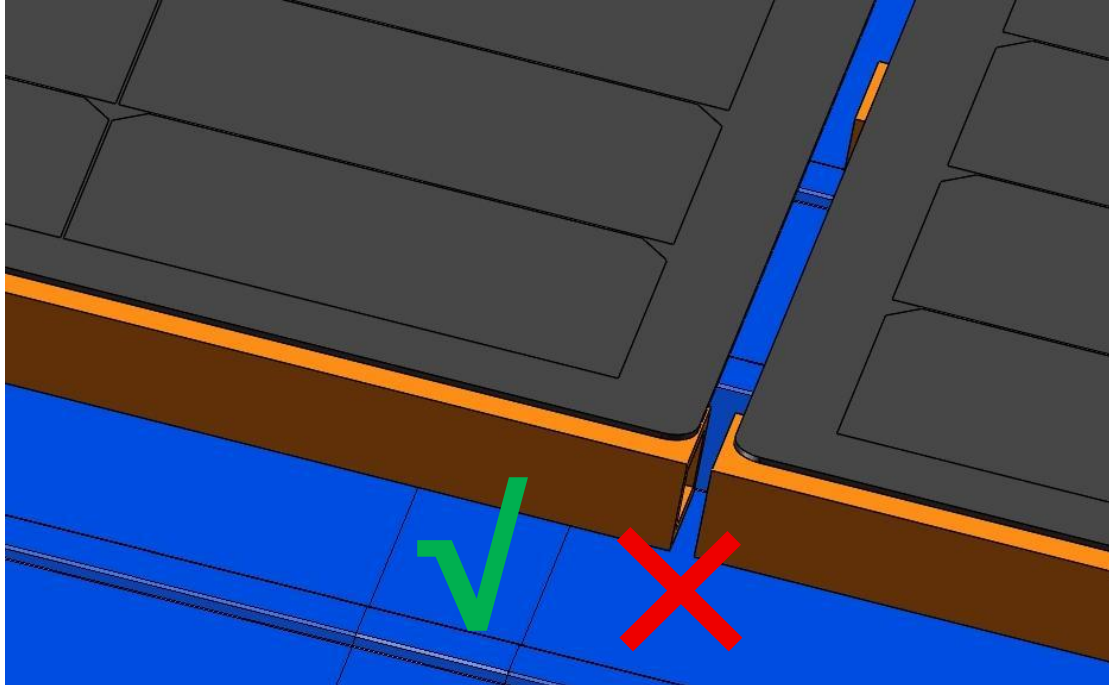

- If there is splicing of the cushion square pipe, the splicing must be between the modules. A single module cannot be covered with square pipe seams;

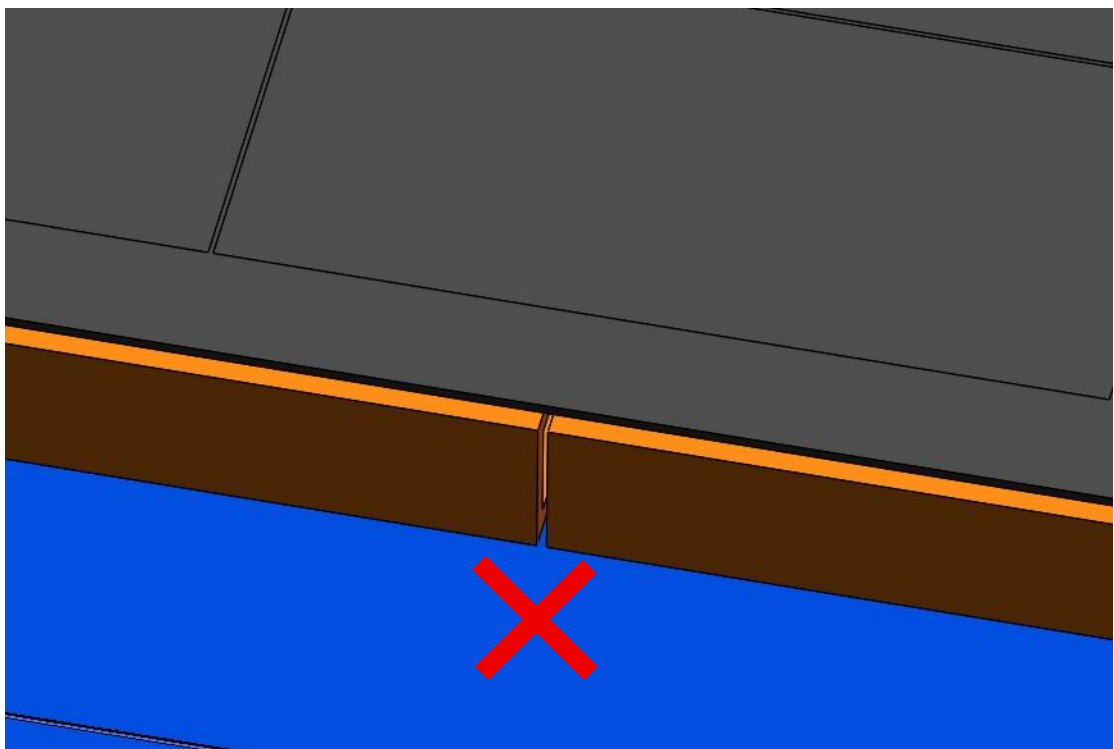
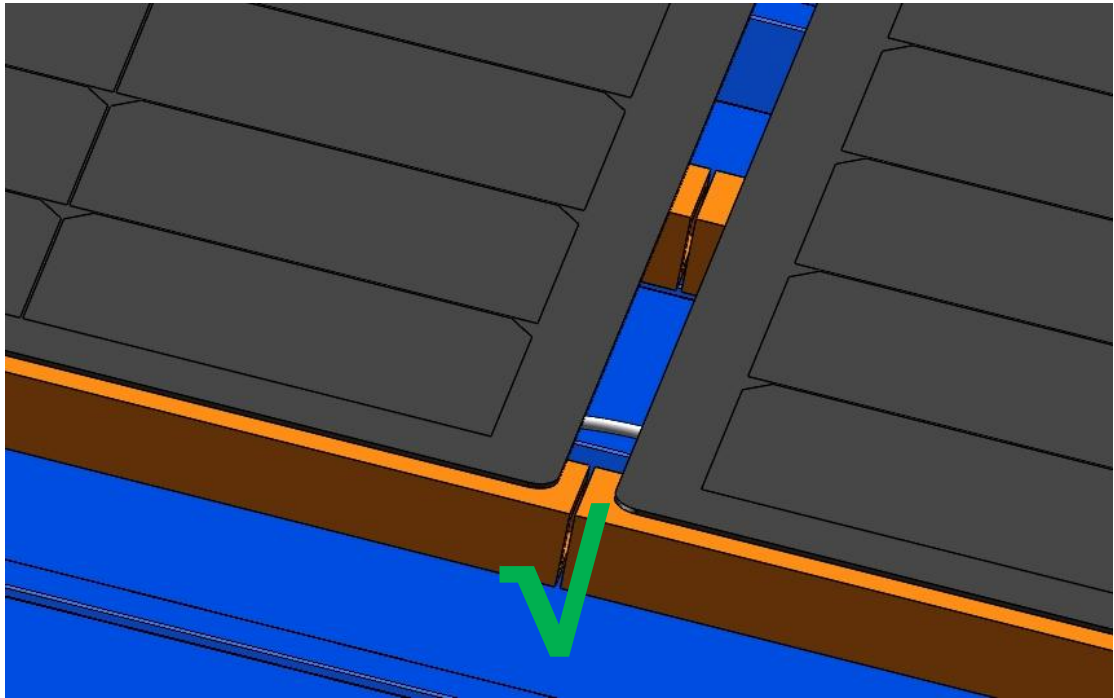

- Install other solar modules by layout and connect the positive and negative connectors.

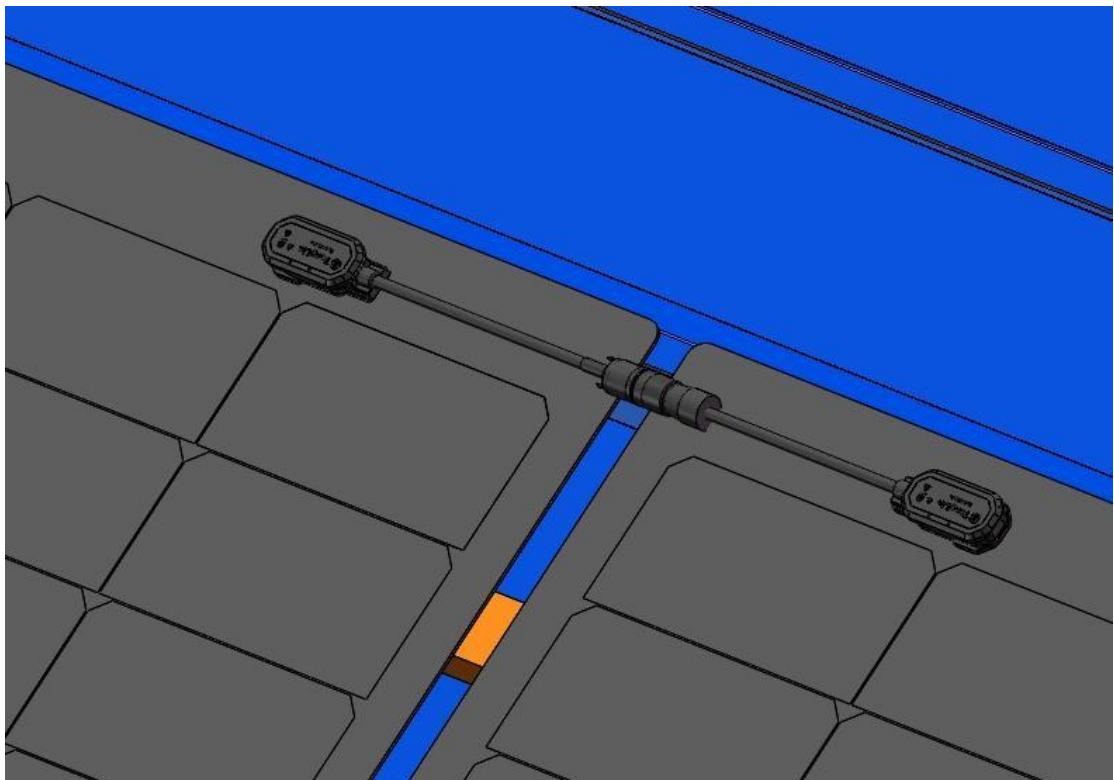
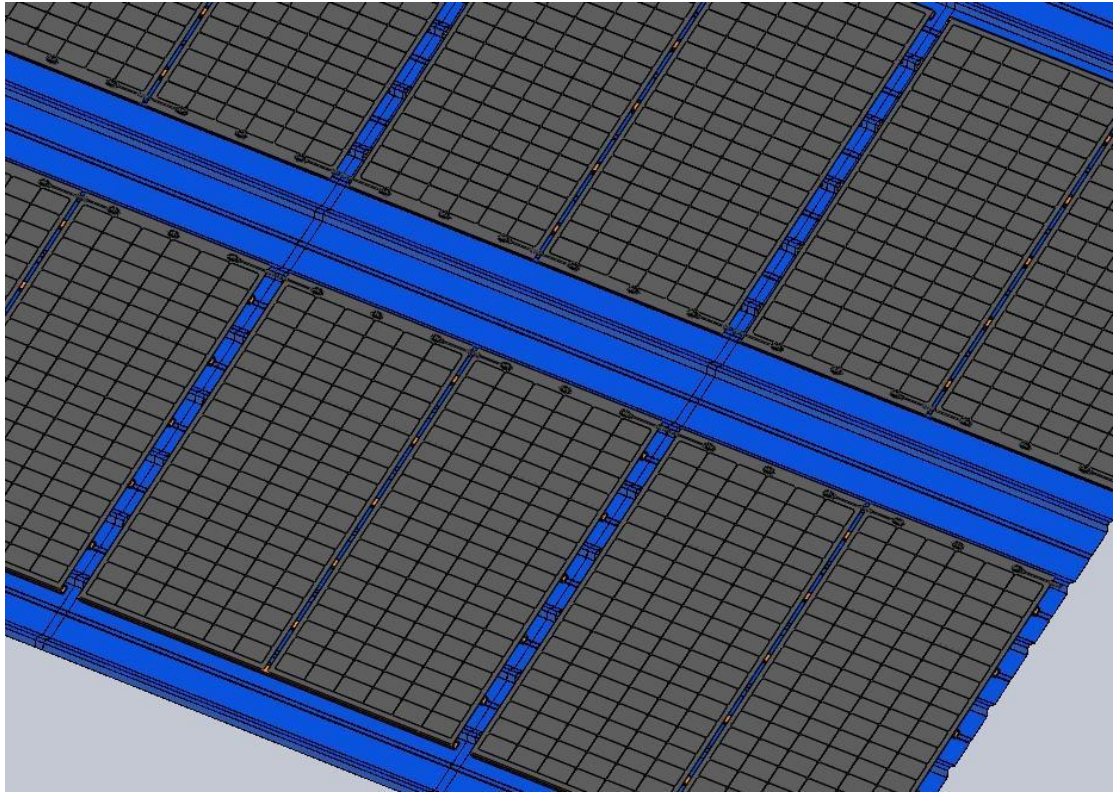

- The minimum distance between modules is 20mm, and the construction and maintenance channel between arrays is 500~800mm (this spacing is for reference only); Adjacent modules share a cushion square tube; Place the junction box on

the side of the access channel to facilitate serial wiring and maintenance inspection.

## 6.7 Vertical wall Construction Scheme

Peakup's flexible lightweight modules are suitable for various types of vertical walls, including concrete walls, metal walls, stone finishes, coatings, glass, ceramic, metal facades. Prior to the installation of the modules on vertical walls, a professional assessment of the wall must be conducted to determine if there is any flaking. For walls prone to flaking, a primer treatment is necessary to ensure that the surface does not delaminate before proceeding with further installation operations.

### 6.7.1 Facade installation method (Longitudinal)

- Cleaning the wall, without particles, dust and other residues;



- Drawing identification lines on the wall (Interval 274mm);

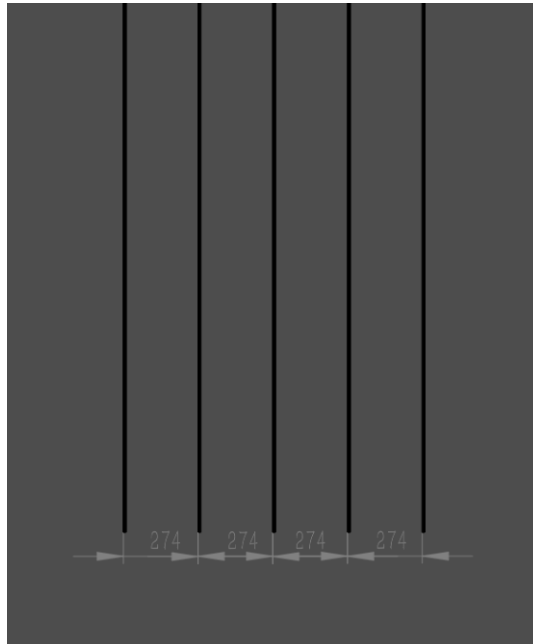

- Position the aluminum alloy mounting rail according to the marked lines and secure it to the wall using screws or glue.

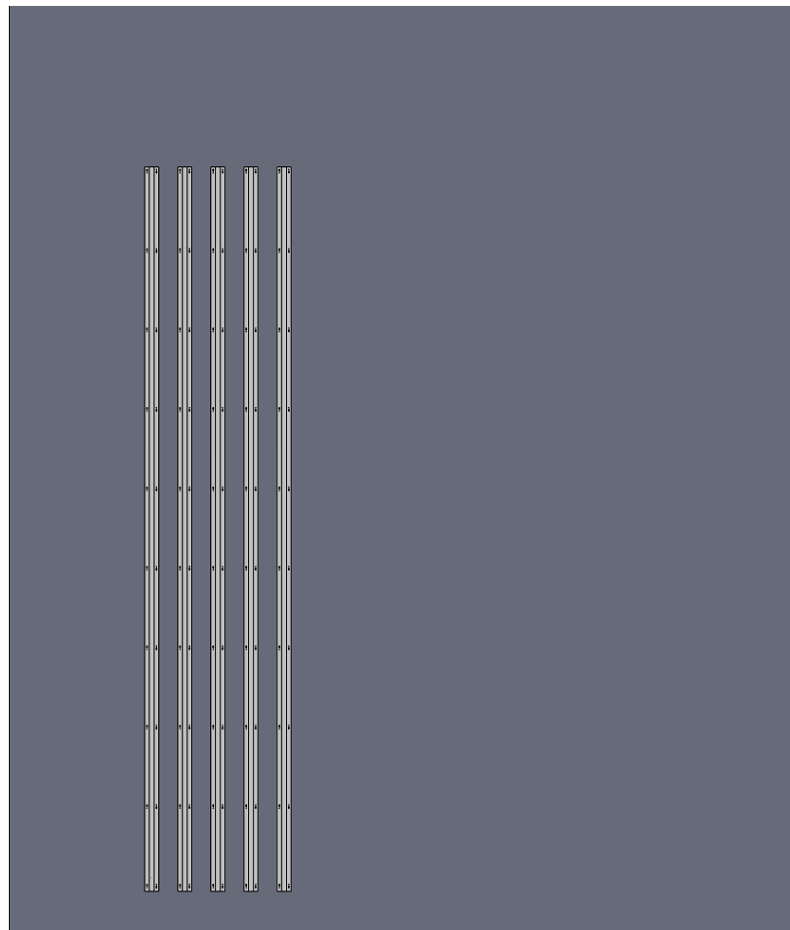

- Paste double-sided tapes on the edge of module;

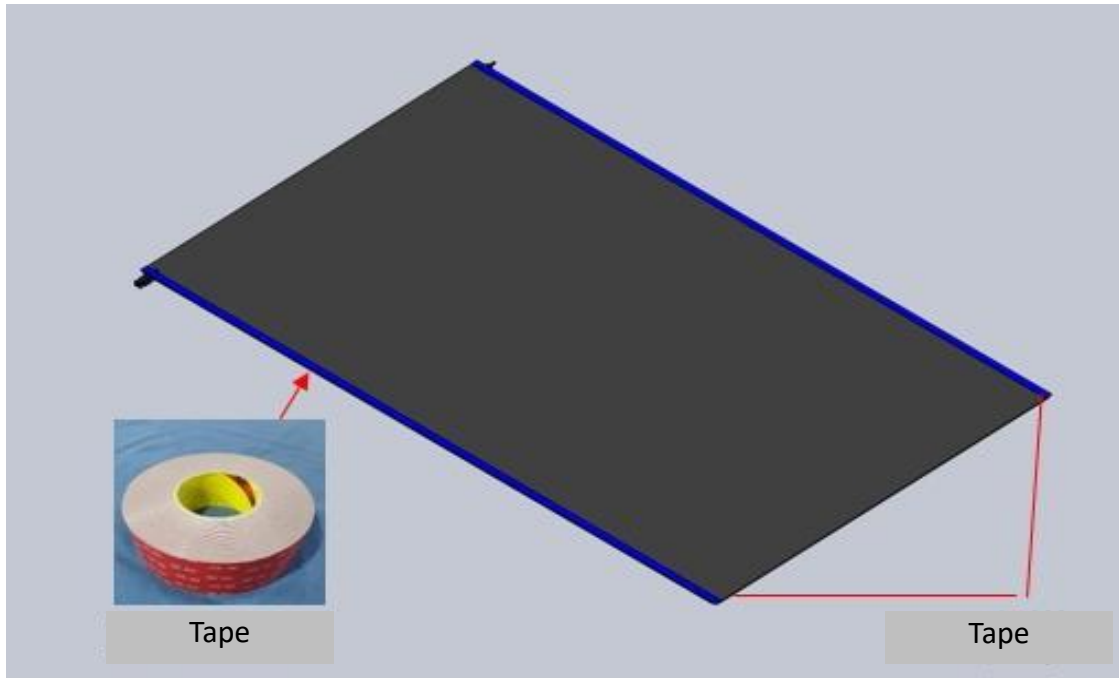

- Apply the glue to the surface of the aluminum alloy profile using a glue gun.

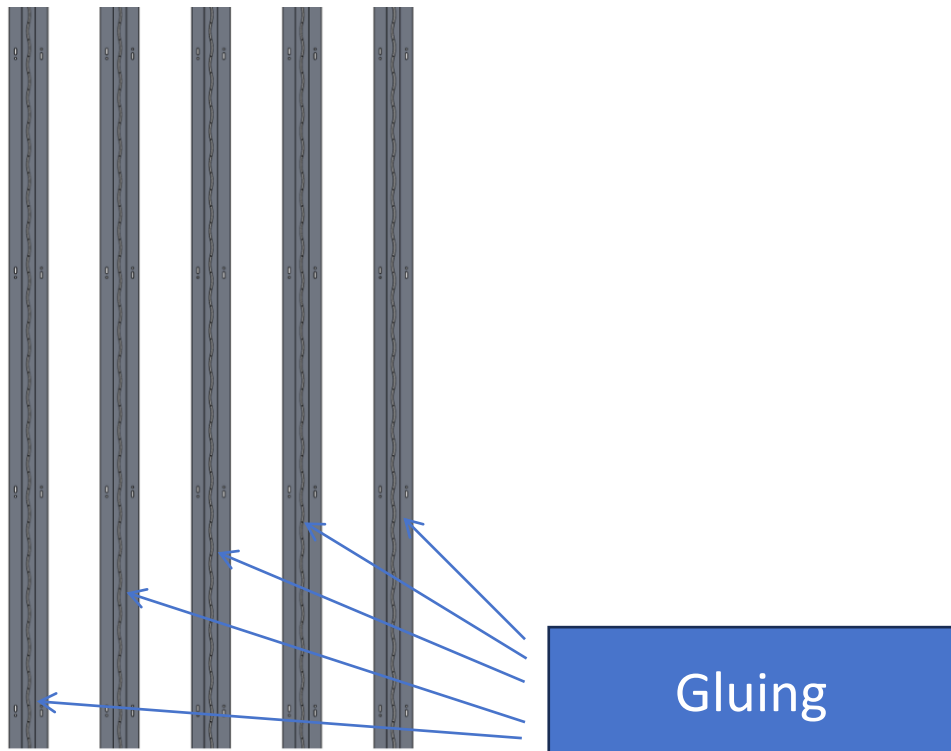

- Install the module and use a brush tool to firmly press along the application area where the module contacts the glue.

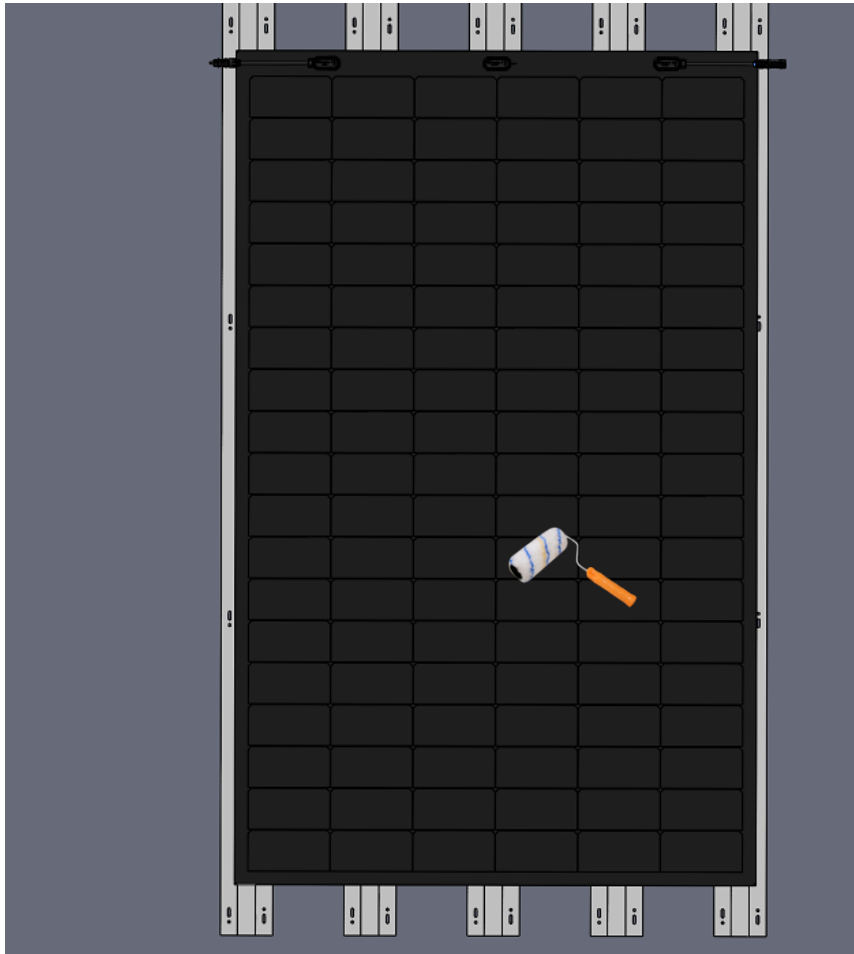

- Install other solar modules by layout and connect the positive and negative connectors.

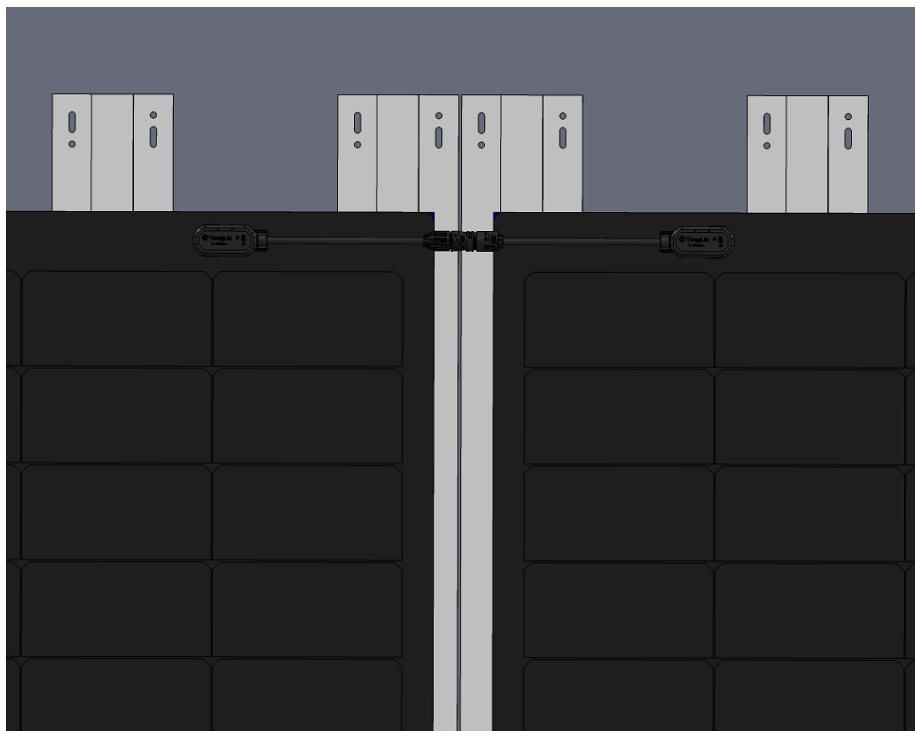
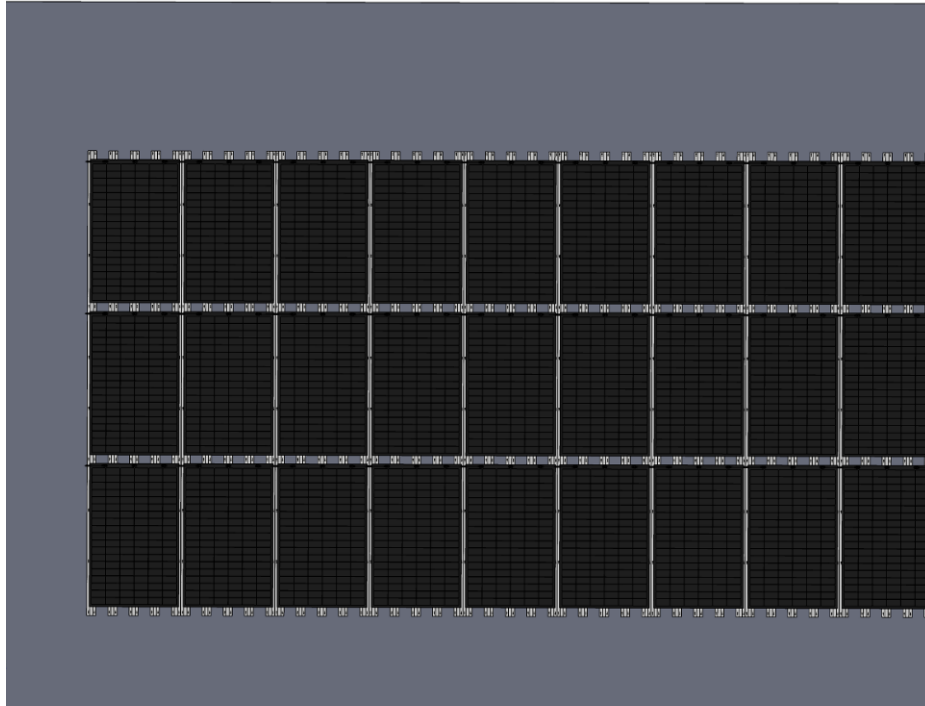

## 6.7.2 Facade installation method (Horizontal)

- Cleaning the wall, without particles, dust and other residues;



- Drawing identification lines on the wall (Interval 302mm);

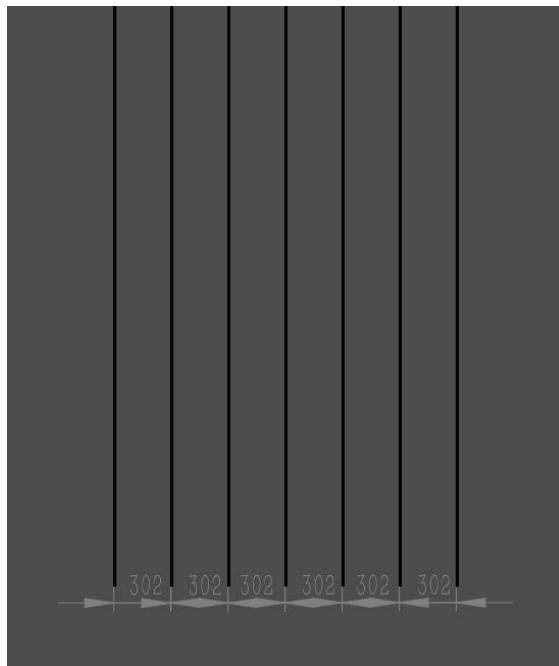

- Position the aluminum alloy mounting rail according to the marked lines and secure it to the wall using screws or glue.

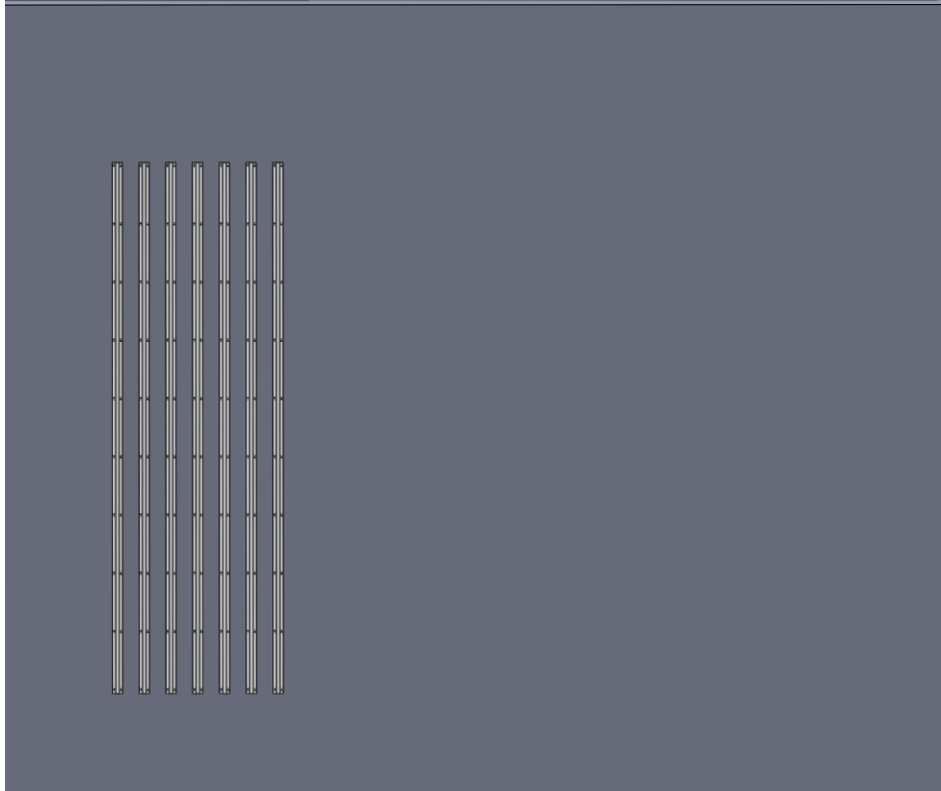

- Paste double-sided tapes on the edge of module;



- Apply the glue to the surface of the aluminum alloy profile using a glue gun.

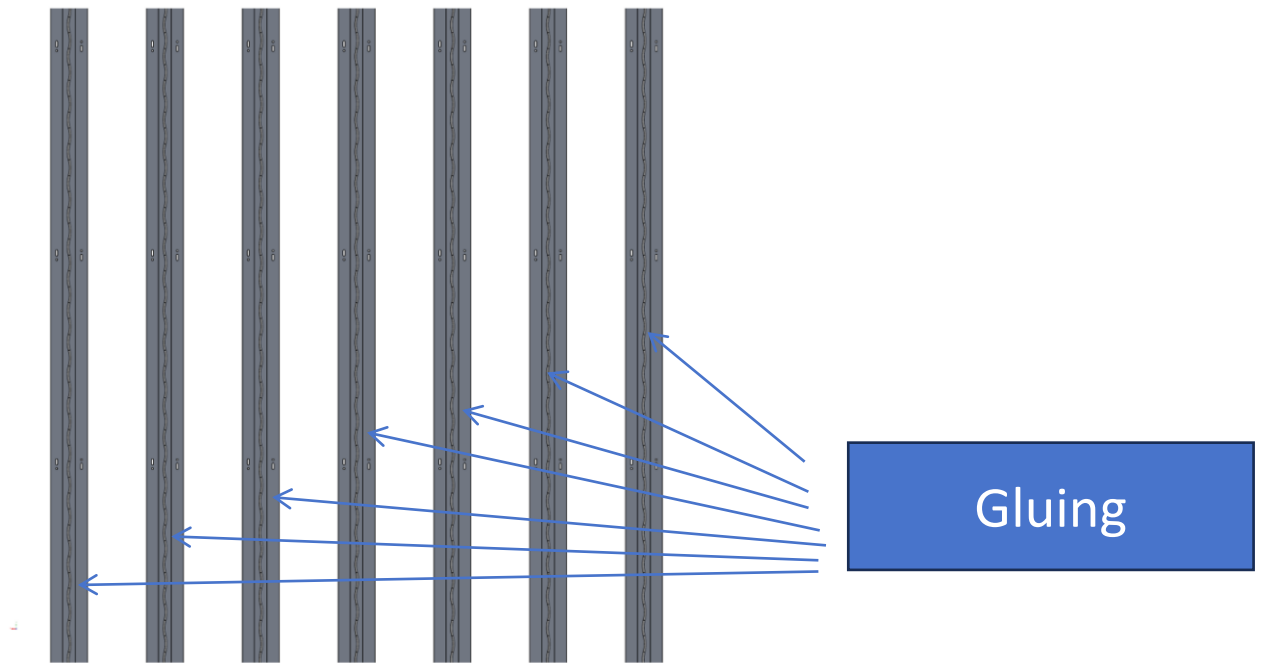

- Install the module and use a brush tool to firmly press along the application area where the module contacts the glue.

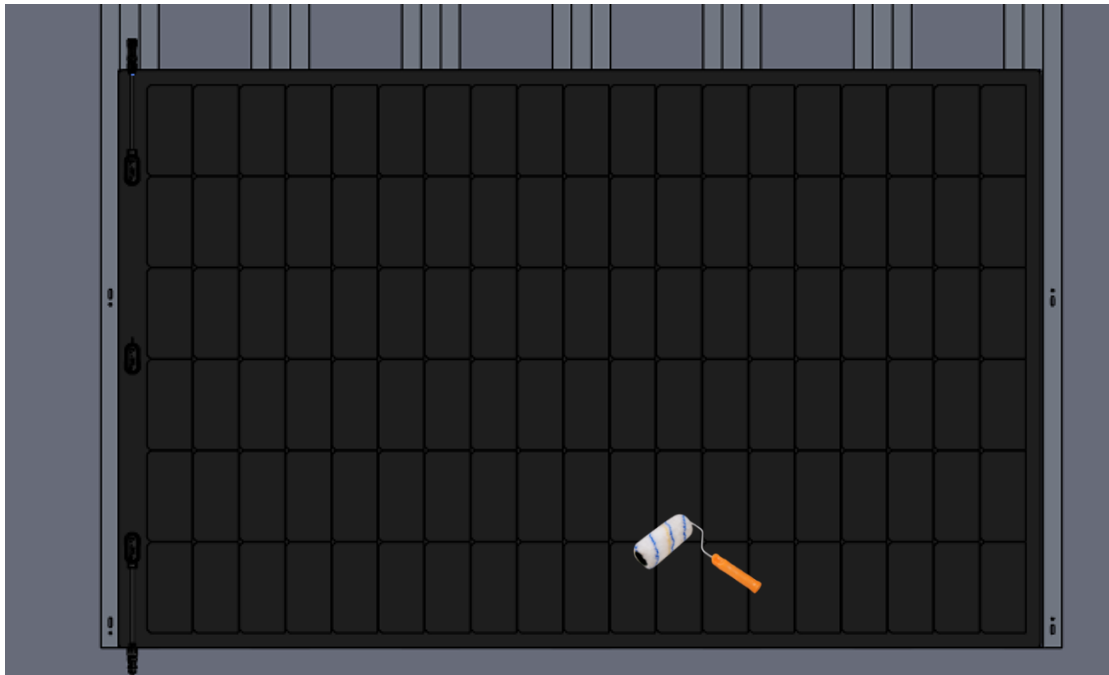

- Install other solar modules by layout and connect the positive and negative connectors.

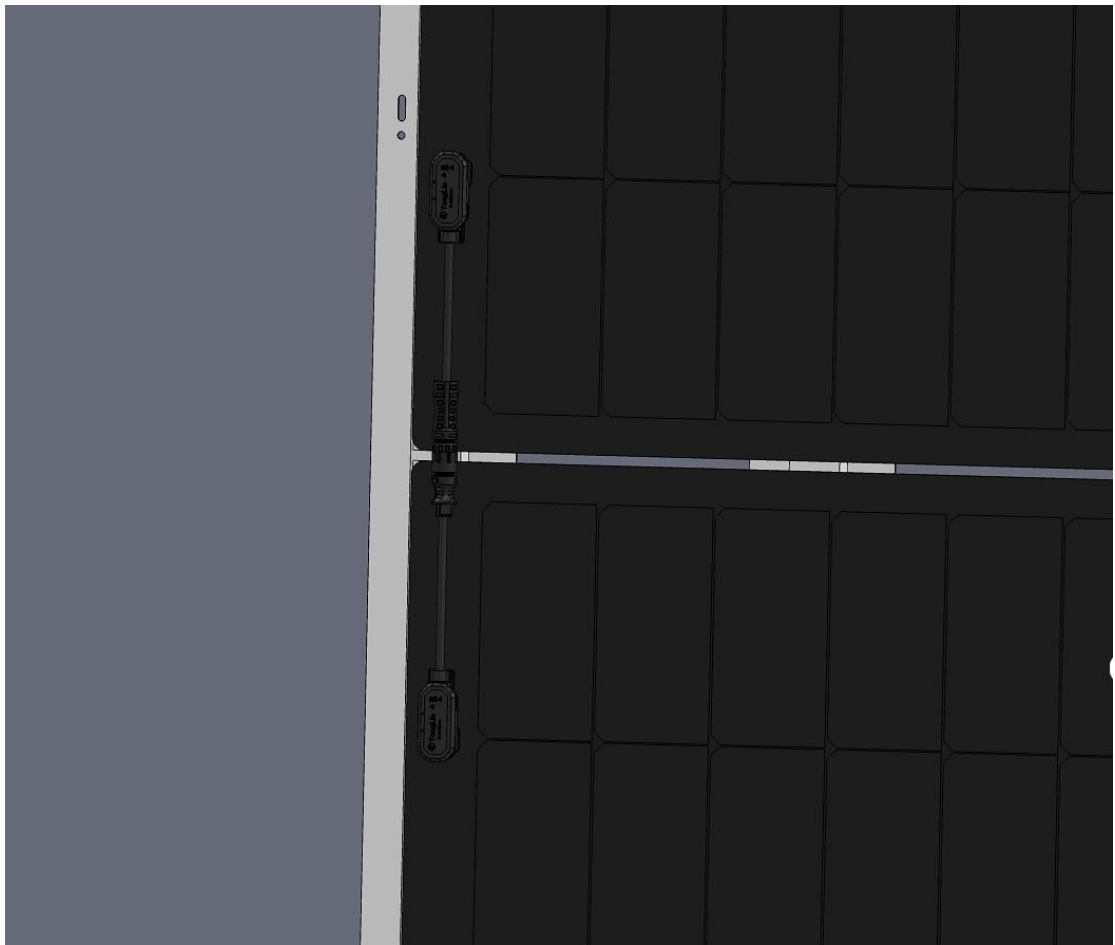
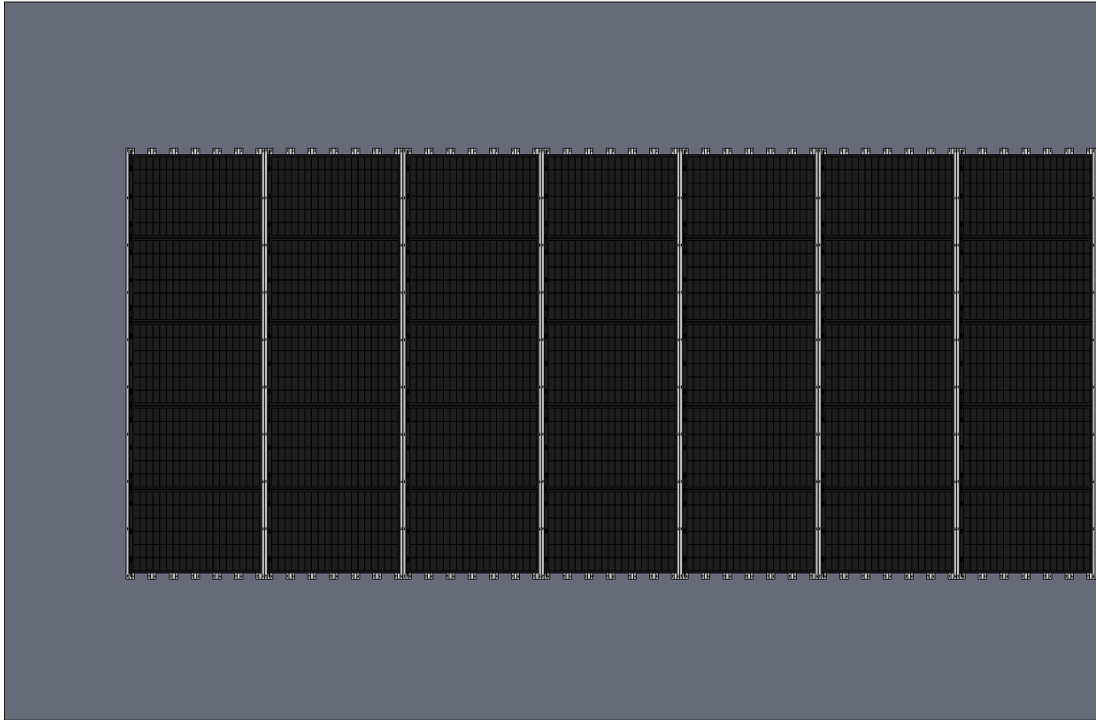

S

## 6.8 Wiring and testing

- The use of PV modules with different electrical characteristics in a PV system is prohibited.
- Excessive cables must be organized or fixed in the proper location, do not cover the cell area.
- For applications requiring high operating voltages, several PV modules may be connected in series to form a PV string, then the system voltage is equal to the sum of the voltages of each PV module.
- For applications requiring high operating currents, several strings of PV modules can be connected in parallel to form a PV string, then the system current is equal to the sum of the currents of each PV module string.
- A maximum system voltage of 1500VDC is allowed.
- The maximum number of PV modules in series depends on the system design, the type of inverter used and the environmental conditions.
- Depending on the maximum series fuse rating of the PV module and local electrical installation codes, if the PV module does not have any fuses or blocking diodes, make sure to connect no more than two strings in parallel.
- There is no limit to the number of PV modules that can be connected in parallel (fuses per string should be considered), the number of PV modules is determined by system design parameters such as current or power output.
- Please refer to local regulations to determine the size, type and temperature of the system conductors.
- PV modules are equipped with connectors for system electrical connections, please refer to local regulations and data sheets that allow the use of connectors.
- **To ensure a reliable electrical connection and to prevent possible moisture ingress, connectors must fit and lock together until a click is heard. Otherwise,**

**arcing and electric shock may occur. Please ensure that all electrical connections are secure and that all locked connectors are fully engaged. ◦**

The DC power generated by the PV system can be converted to AC power and connected to the public grid, as the local power company's policy for connecting renewable energy systems to the grid varies from region to region. You can ask your PV system design engineer or integrator for help in obtaining building permits, inspections, and approvals from your local power company's department.

## **7 Maintenance and repair**

Peakup recommends that PV systems shall be periodically inspected by the installer or qualified person.

### **7.1 Maintenance**

Regular inspections should be conducted, with corresponding inspection content set for different periods.

#### **7.1.1 Daily Remote Monitoring**

- Daily verification of power generation, string current/voltage, and temperature via monitoring system.
- Immediate on-site troubleshooting if abnormalities are detected:
  - Power deviation > 10%
  - Abrupt drop in string current
  - Abnormal voltage or temperature

#### **7.1.2 Monthly Inspection**

##### **7.1.2.1 PV Module Appearance**

- Check for cracks, micro-cracks, delamination, bulging, scratches.
- Remove bird droppings, moss, dust, and dirt.

##### **7.1.2.2 Adhesive & Sealing System**

- Inspect module edge adhesion to roof: debonding, lifting, gaps, water ingress.

- Check sealant for aging, cracking, or deterioration.

#### 7.1.2.3 Roof Drainage

- Inspect low-slope roofs (1–2%) for ponding, stagnant water, poor drainage.
- Clean all roof drains and outlets.

#### 7.1.2.4 Junction Boxes

- Check sealing, water ingress, burning, discoloration, and loose terminals.

#### 7.1.2.5 Module Cleaning

- Monthly: dusty / industrial / coastal areas
- Quarterly: rainy regions with low dust

### **7.1.3 Quarterly Inspection**

- Adhesive system: check for debonding, hollow gaps, insufficient adhesion.
- Roof substrate: inspect settlement, cracks, water seepage that may affect adhesion.
- Drainage system: full dredging, verify slope and drainage capacity.
- Electrical system: insulation resistance, grounding, lightning protection.
- Mechanical structure: module flatness, displacement, and fastening.

### **7.1.4 Annual Comprehensive Inspection**

- Adhesive system: evaluate bond strength; reapply or repair sealant as needed.
- Waterproofing & drainage: rectify ponding issues on low-slope roofs.
- Extreme condition adaptability: snow load, high/low temperature performance.
- Documentation: update O&M records and warranty compliance report.

### **7.1.5 Special & Emergency Inspection**

#### 7.1.5.1 After Extreme Weather

- Mandatory inspection within 48 hours after strong wind, rainstorm, blizzard, or hail.
- Check: structure, adhesion, drainage, component damage, waterproofing.

#### 7.1.5.2 After Abnormal Events

- Immediate inspection: water leakage, abnormal noise, sudden power drop, fire hazards.

#### 7.1.5.3 Seasonal Preventive Inspection

- Before rainy season: focus on drainage and waterproofing.
- Before winter: snow load capacity and de-icing measures.

maintenance personnel should wear rubber gloves and insulated boots at all times during their work to remove any obstructions that may obscure the solar modules and thus affect their performance.

Check that the installed hardware is fastened in place.

During inspection and maintenance, it is strictly forbidden to step on the panels, and it is prohibited to place heavy objects, tools, or sharp items on them. During operation and maintenance, avoid dropping tools or impact from hard objects to prevent hidden cracks or surface scratches.

## 7.2 Repair

If the module is damaged, it must be replaced. The replacement module must be of the same type. When replacing modules, do not touch the live parts of the cables and connectors. Appropriate safety protective equipment (insulated tools, insulated gloves, insulated boots, etc.) should be used when handling modules.

When replacing the module, remove the untouched structural adhesive position, clean the adhesive with a cleaning solvent, and then re-install and connect the wiring according to the module installation method.

## 7.3 Cleaning and method recommended

In order to reduce the potential for electrical and thermal shock, Peakup recommends cleaning modules during early morning or late afternoon hours when solar radiation is low and the modules are cool, especially in regions with high temperatures.

When modules are working, there should not be environmental influence factors to cast shadows and cover part or even all of the modules, such as other modules,

system support, bird drops and a lot of dust, clay or plant and so on, these may distinctly reduce the power output. Peakup advises that there should be no obstructed object over the modules surface at any time.

The cleaning frequency depends on the accumulated frequency of the fouling. In many instances the front surfaces of the modules will be cleaned with the rain, and we can decrease the cleaning frequency. In order to avoid module damage, do not clean PV modules with a power washer or pressure washer, it is recommended to wipe the modules surface with a wet sponge or soft cloth. Please do not clean the modules with a cleaning agent which contains acid or alkali. However, if removing snow is desired to enhance production, use a brush to gently remove snow. Avoid the patchy phenomenon of "some snow and some no snow" on photovoltaic modules. Do not try to remove frozen snow or ice from the modules. It is strictly forbidden to attempt to clean PV modules with features such as broken panels, exposed wires, etc., as there is a risk of receiving electric shock.

**Method A:** High-pressure water flow cleaning

Water Quality Requirements: PH: 5-7;

Water hardness: calcium carbonate concentration  $\leq$  600mg/L

Chloride or salt content: 0-3000mg/L

Demineralized water is recommended

It is recommended to use a water pressure of no more than 70kPa

**Method B:** Wet wipe clean

If there are too many stains on the surface of the module, you can use a sponge to wipe the surface of the module with water, a dust-free cloth with alcohol, a soft brush or a soft mop cloth. Make sure the tool is constructed of insulating material and has protective measures in place to minimize the risk of electric shock. If oil stains are present, they can be cleaned with caution using environmentally friendly, non-corrosive detergents.

## Annex A: Unpacking

Standard unpacking procedures for photovoltaic modules:



1、 Preparation of unpacking tools, including scissors, specialized module jigs, and anti-slip gloves.

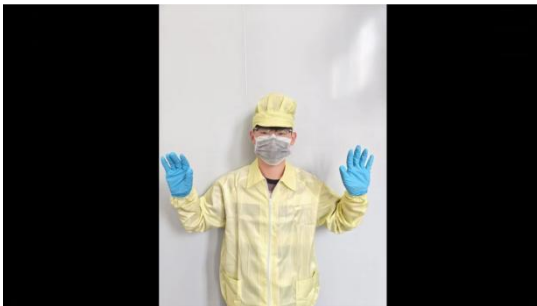

2、 The unpacking personnel should wear their uniforms, put on protective goggles, and use anti-slip gloves.



3、 Use scissors to remove all external wrapping film and packaging straps.



4、 Lift the outer box.



5、 Cut off the second layer of packing tape.



6、 Remove the four sides of the frame.



7、 Lift the top cardboard plate.



8、 Cut off the third layer of packing tape.



9、 Lift the top cover.



10、 To take the modules, ask two people to use the special clamp for the modules, grab them from the short side of the modules and lift them out of the fence.

#### Unboxing precautions

- When opening the carton outdoors, avoid operating in rainy weather;
- When working outdoors with wind, fixed measures should be taken to disassemble the modules;
- Before unpacking, stack the modules in a ventilated, rainproof and dry area;
- When using scissors or utility knives to cut the outer packaging strap, do not scratch the front or back of the assembly;
- After unpacking, the number of modules in the box should be confirmed in time;
- The unpacking area needs to ensure that the packaging box is placed horizontally and stably to avoid modules from tipping over.
- During unpacking and handling, please wear protective gloves correctly to avoid scratches;
- Under no circumstances should you pull the junction box or cables;
- Grip the modules and do not touch the cell area with your hands.

## Annex B: Model and electrical performance parameters

No.	Type	STC					Remark
		Pmp	Vmp	Imp	Voc	Isc	
1	PKQJH57I425 (2 <sup>nd</sup> )	425	34.96	12.16	41.61	13.03	Normal frontsheet and backsheet
2	PKQJH57J420 (2 <sup>nd</sup> )	420	34.74	12.1	41.39	12.95	
3	PKQJH57I425 (3 <sup>rd</sup> )	425	34.96	12.16	41.61	13.03	Fire retardant frontsheet and backsheet
4	PKQJH57J420 (3 <sup>rd</sup> )	420	34.74	12.1	41.39	12.95	

## Annex C: Gluing operation specification

### 1. Gluing nozzle cutting

The standard nozzle cutout is 10.5mm x 6mm, which is made by cutting about 20mm from the original nozzle and flattening it to the required size, as shown in the figure below.

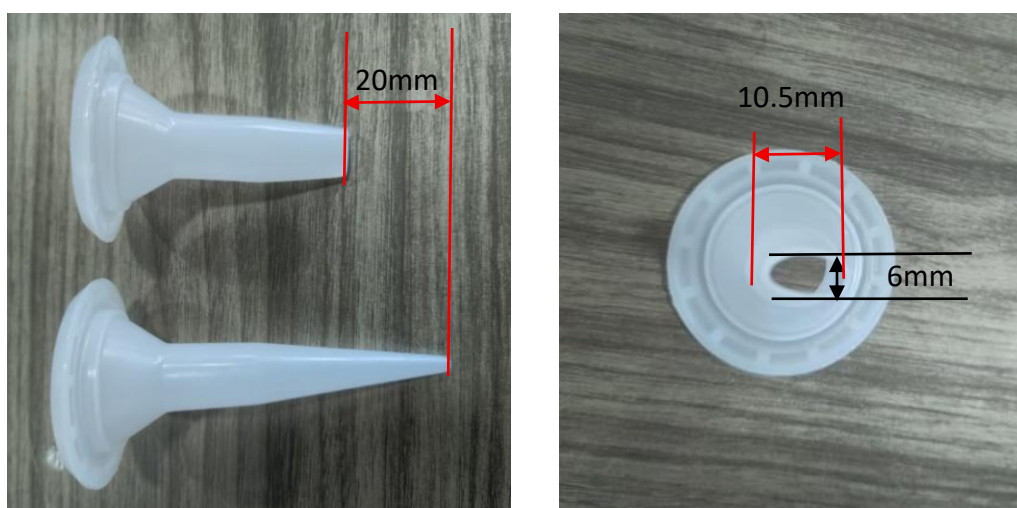

Nozzle cutting should be carried out in strict accordance with the following procedures.



Standard tool shears

## 2. Operation steps



1. Use a straightedge or tape measure to measure the length of the head of the nozzle 20mm, confirm the cutting position, and then use the tool to cut in addition.



2. It is recommended to use a lighter to heat the tip of the rubber nozzle for about 2s to prevent it from springing back after being flattened.



3. Squeezing of the nozzle to the desired size using a flattening die of the tool shears.

### 3. Gluing parameters

Gluing angle: the glue gun is at an angle of about  $40^\circ$  with the ground, as shown in the following figure:





Adhesive size and standard dosage: at least 10\*5mm; 5 strips/1 module (adhesive along the width of the PV module); 3 strips/1 module (adhesive along the length of the PV module).

#### 4. Structural adhesive form

Please read below for the correct structural adhesive application.

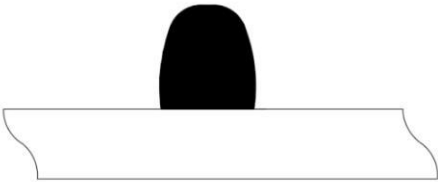
<p>✓ Correct dimension</p>	<p>✗ Too flat</p>

	
<p>✗ Too high, too small</p>	<p>✗ Poor wetting</p>

The correct form of structural adhesive after pasting modules.

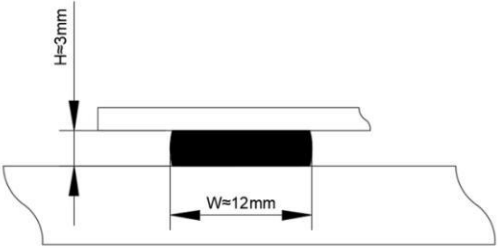
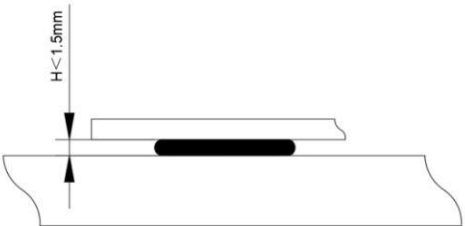
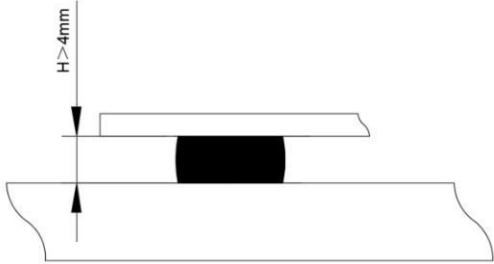
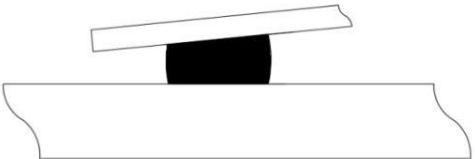
 <p>H=3mm W=12mm</p>	 <p>H &lt; 1.5mm</p>
<p>✓ Correct dimension</p>	<p>✗ Too flat</p>
 <p>H &gt; 4mm</p>	
<p>✗ Too high</p>	<p>✗ Inclined</p>